



Power Amplifier



MC2KW Owner's Manual

The lightning flash with arrowhead, within an equilateral triangle, is intended to alert the user to the presence of uninsulated "dangerous voltage" within the product's enclosure that may be of sufficient magnitude to constitute a risk of electric shock to persons.



AVIS RISQUE DE CHOC ELECTRIQUE - NE PAS OUVRIR.

The exclamation point within an equilateral triangle is intended to alert the user to the presence of important operating and maintenance (servicing) instructions in the literature accompanying the appliance.

WARNING - TO REDUCE RISK OF FIRE OR ELECTRICAL SHOCK, DO NOT EXPOSE THIS EQUIPMENT TO RAIN OR MOISTURE.

NO USER-SERVICEABLE PARTS INSIDE. REFER SERVICING TO QUALIFIED PERSONNEL.

To prevent the risk of electric shock, do not remove cover or back. No user-serviceable parts inside.

IMPORTANT SAFETY INSTRUCTIONS!

PLEASE READ THEM BEFORE OPERATING THIS EQUIPMENT.

1. Read these instructions.
2. Keep these instructions.
3. Heed all warnings.
4. Follow all instructions.
5. Do not use this apparatus near water.
6. Clean only with a dry cloth.
7. Do not block any ventilation openings. Install in accordance with the manufacturer's instructions.
8. Do not install near any heat sources such as radiators, heat registers, stoves, or other apparatus (including amplifiers) that produce heat.
9. Do not defeat the safety purpose of the polarized or grounding-type plug. A polarized plug has two blades with one wider than the other. A grounding type plug has two blades and a third grounding prong. The wide blade or the third prong are provided for your safety. If the provided plug does not fit into your outlet, consult an electrician for replacement of the obsolete outlet.
10. Protect the power cord from being walked on or pinched particularly at plugs, convenience receptacles, and the point where they exit from the apparatus.
11. Only use attachments/accessories specified by the manufacturer.
12. Use only with the cart, stand, tripod, bracket, or table specified by the manufacturer, or sold with the apparatus. When a cart is used, use caution when moving the cart/apparatus combination to avoid injury from tip-over.
13. Unplug this apparatus during lightning storms or when unused for long periods of time.
14. Refer all servicing to qualified service personnel. Servicing is required when the apparatus has been damaged in any way, such as power-supply cord or plug is damaged, liquid has been spilled or objects have fallen into the apparatus, the apparatus has been exposed to rain or moisture, does not operate normally, or has been dropped.
15. Do not expose this equipment to dripping or splashing and ensure that no objects filled with liquids, such as vases, are placed on the equipment.
16. To completely disconnect this equipment from the a.c. mains, disconnect the power supply cord plug from the a.c. receptacle.
17. The mains plug of the power supply cord shall remain readily operable.
18. **This apparatus is capable of driving Loudspeakers (even low efficiency types), into producing extremely high sound pressure levels. User caution is advised. Ear protection is recommended when playing at high volumes as continued exposure to high sound pressure levels can cause permanent hearing impairment or loss.**
19. Do not place the protective blue cloth cover on the equipment when the power supply cord is connected.



Thank You

Your decision to own this McIntosh MC2KW Power Amplifier ranks you at the very top among discriminating music listeners. You now have “The Best.” The McIntosh dedication to “Quality,” is assurance that you will receive many years of musical enjoyment from this unit.

Please take a short time to read the information in this manual. We want you to be as familiar as possible with all the features and functions of your new McIntosh.

Please Take A Moment

The serial number, purchase date and McIntosh Dealer name are important to you for possible insurance claim or future service. The spaces below have been provided for you to record that information:

Serial Number: _____

Purchase Date: _____

Dealer Name: _____

Technical Assistance

If at any time you have questions about your McIntosh product, contact your McIntosh Dealer who is familiar with your McIntosh equipment and any other brands that may be part of your system. If you or your Dealer wish additional help concerning a suspected problem, you can receive technical assistance for all McIntosh products at:

McIntosh Laboratory, Inc.
 2 Chambers Street
 Binghamton, New York 13903
 Phone: 607-723-1545
 Fax: 607-724-0549

Customer Service

If it is determined that your McIntosh product is in need of repair, you can return it to your Dealer. You can also return it to the McIntosh Laboratory Service Department. For assistance on factory repair return procedure, contact the McIntosh Service Department at:

McIntosh Laboratory, Inc.
 2 Chambers Street
 Binghamton, New York 13903
 Phone: 607-723-3515
 Fax: 607-723-1917

Table of Contents

Safety Instructions 2
 Thank You and Please Take a Moment 3
 Technical Assistance and Customer Service 3
 Table of Contents 3
 Important Information and Connector Information 4
 Introduction 4
 Performance Features 5
 Dimensions 6-7
 Installation 8-9

Connections:

MC2KW Output Module Rear Panel Connections 10
 MC2KW Power Module Rear Panel Connections 11
 How to Connect the MC2KW Output Module and Power Modules together; for Power Control and Audio Connections 12-13
 How to Connect the MC2KW Output Module to Loudspeakers 14-15

Front Panel Features:

MC2KW Output Module Front Panel Controls and Displays 16
 MC2KW Power Module Front Panel 16

Operation:

How to Operate the MC2KW Power Amplifier 17

Additional Information:

Technical Description 18
 Photos 23-27
 Block Diagram 29
 Specifications 30
 Packing Instruction 31

Important Information

Caution: The MC2KW Power Module weight is 158 pounds (71.7 kilograms) and the MC2KW Output Module weight is 121 pounds (54.9 kilograms). It requires two or more persons to safely handle when moving the Power or Output Module.

1. The MC2KW Power Amplifier consists of one MC2KW Output Module and two MC2KW Power Modules.
2. The following Connecting Cable is available from the McIntosh Parts Department:
 - Power Control Cable Part No. 170-202**
Six foot, 2 conductor shielded, with two 1/8 inch stereo mini phone plugs.
 - Power Module to Output Module Cable Part No. 171-611**
Three foot, shielded 21 conductor, low current, male-to-male custom cable, one required between each MC2KW Power Module and MC2KW Output Module.
 - Power Module to Output Module Cable Part No. 171-620**
Three foot, shielded 16 conductor, high current, male-to-male custom cable, one required between each MC2KW Power Module and MC2KW Output Module.
3. For additional connection information, refer to the owner's manual(s) for any component(s) connected to the MC2KW Power Amplifier.
4. It is very important that loudspeaker cables of adequate size be used, so that there will be no power loss. The size is specified in Gauge Numbers or AWG (American Wire Gauge). The smaller the Gauge number, the larger the wire size:
 - If your loudspeaker cables are 50 feet (38.1m) or less, use at least 12 Gauge.
 - If your loudspeaker cables are 100 feet (76.2m) or less, use at least 10 Gauge.
5. The MC2KW Power Amplifier incorporates the very latest in Fully Double Balanced Circuitry. As a result, the Loudspeaker Negative \ominus Connections are above chassis ground. Do not combine any connections together, ground them or connect with another MC2KW Power Amplifier.
6. Each of the MC2KW Power Modules needs to be connected to a dedicated AC Circuit with Outlet. The type and size of the dedicated AC Circuit with Outlet needs to be in accordance with the Local Electrical Wiring Codes¹. Always contact your McIntosh Dealer and Certified Electrician for addition information and assistance. The MC2KW Output Module should be connected to a third separate AC Circuit with Outlet. The third AC Circuit with Outlet may also have other McIntosh and Non-McIntosh Component(s) connected, including additional MC2KW Output Modules.

¹ 20 Amp, 120Volt AC Circuit is for use in the United States and Canada only.

7. The AC Power Cables going to the MC2KW Power Modules, MC2KW Output Module and any other McIntosh Component(s) should not be connected to AC Power Outlets until all the system components are connected together.
8. The MC2KW Power Amplifier mutes the speaker output for approximately two seconds when first turned on.
9. In the event that either or both MC2KW Power Modules over heat, due to improper ventilation and/or high ambient temperature, the protection circuits will activate. The sound will be muted and the MC2KW Output Module Front Panel Power Guard LED will continuously indicate ON. When the MC2KW Power Modules have returned to a safe operating temperature, normal operation will resume.
10. Each MC2KW Power Module connects to the MC2KW Output Module with two different supplied custom cables. If both cables, from each MC2KW Power Module, are not connected correctly to the MC2KW Output Module, the MC2KW Power Amplifier will not power up. Refer to pages 12 and 13 for additional information on connecting the MC2KW Power Modules to the MC2KW Output Module.

Connector Information

XLR Connectors

Below is the Pin configuration for the XLR Balanced Input and Output Connectors on the MC2KW Output Module.

Refer to the diagram for connection:

- PIN 1: Shield/Ground
- PIN 2: + Signal
- PIN 3: - Signal

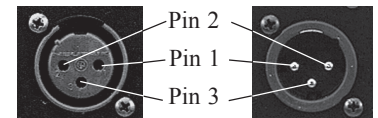

Power Control Connectors

The MC2KW Output Module Power Control Input and Output utilize a 5 volt signal. There is an additional connection for controlling illumination of the MC2KW Output Module Power Output Meter. Use a 1/8 inch stereo mini phone plug to connect to the Power Control Input on other McIntosh Components.

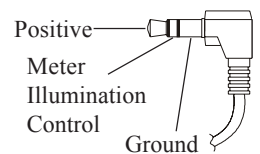

Introduction

The MC2KW Power Amplifier with a Triple Chassis Mono Block Design is the most powerful and finest audio Power Amplifier McIntosh has ever created. No design compromises were allowed in the quest for a Power Amplifier with absolute accuracy, total sonic purity and virtual elimination of distortion and audible noise. It is capable of driving even the most inefficient Loudspeakers to live concert hall volume levels with a degree clarity never before achieved. For those who have been searching for the “Best in a Power Amplifier”, your wait is over.

Performance Features

● Triple Chassis Mono Block Design

For the first time, the new McIntosh MC2KW Power Amplifier is capable of supplying the power required to reproduce the full dynamic range of a symphony orchestra including pipe organ. This includes driving low efficiency Loudspeakers in a large room to concert hall volume levels. It can reproduce complex music with complete accuracy, with no added distortion or noise. The Triple Chassis Design also allows for easier placement in a room than would be possible in a single chassis design, yet with no compromise in performance or reliability.

● Power Output

The MC2KW Power Amplifier is capable of 2,000 watts into 2, 4 or 8 ohm speakers with less than 0.005% distortion. It can provide peak current of 200 amperes and over 8,000 watts of power output on music bursts.

● Full Balanced Quad-Differential Circuitry

The MC2KW Power Amplifier is fully balanced from inputs to outputs. It consists of two matched MC2KW Power Modules, each operating in push-pull with their outputs combined in a McIntosh Autoformer located in the MC2KW Output Module. This double balanced configuration cancels virtually all distortion.

● Patented Power Guard

The patented McIntosh Power Guard circuit prevents the amplifier from being overdriven into clipping, with its harsh distorted sound that can also damage Loudspeakers.

● Patented Sentry Monitor and Thermal Protection

McIntosh Sentry Monitor power output stage protection circuits ensuring each MC2KW Power Module will have a long and trouble free operating life. Built-in Thermal Protection Circuits guard against overheating.

● Patented Autoformer

McIntosh designed and manufactured Output Autoformers provide an ideal match between the amplifier output stages and speaker loads of 2, 4 and 8 ohms. The Autoformers also provide perfect DC protection for your valuable Loudspeakers.

● Illuminated Power Meter

The Illuminated Power Output Watt Meter is peak responding, and indicates the true power output of the amplifier. The Peak Watt Hold Mode allows the meter to temporarily stay at the highest power output and then slowly decay.

● Power Control

The McIntosh Power Control Circuit allows for remote turn-on of the MC2KW Power Amplifier from a McIntosh Audio/Video Control Center or Preamplifier. If any additional McIntosh Power Amplifiers are part of the system, there is a delayed Power Control Output. This delayed trigger reduces the strain on the house's electrical wiring and protection devices.

● Balanced Inputs and Gold Plated Outputs

Balanced connections guard against induced noise and allow long cable runs without compromising sound quality. There are three sets of gold plated five way binding posts for each of the three output impedances.

● Precision Parts

All resistors are precision metal film type. Low dielectric absorption film capacitors are used in all critical circuit locations.

● Fiber Optic Solid State Front Panel Illumination

The Illumination of the 1/2 inch thick laser etched Front Panel Glass is accomplished by the combination of custom designed Fiber Optic Light Diffusers and Light Emitting Diodes (LEDs). This provides even Front Panel Illumination, together with the extra long life LEDs.

● Glass Front Panel and Super Mirror Chassis Finish

The famous McIntosh Illuminated Glass Front Panel with a Stainless Steel Chassis with Super Mirror Finish ensures the pristine beauty of the MC2KW will be retained for many years.

● Machined Top and Side Panels

The Top and Sides of the MC2KW Output and Power Modules are machined from thick aluminum panels with a smooth black anodized finish. There is a screened glass panel in the recessed areas of the Top Panel, with a block diagram of the Circuitry.

● Special Power Supplies

The MC2KW Output Module utilizes a special R-Core Power Transformer together with an electronically fully regulated Power Supply Circuitry. The MC2KW Power Modules each utilize a large Toroidal Wound Power Transformer with large filter capacitors capable of storing 430 Joules of energy.



Dimensions

The following dimensions can assist in determining the best location for the MC2KW Output Module and MC2KW Power Modules. There is additional information on page 8 pertaining to installing the MC2KW Output Module and MC2KW Power Modules into cabinets.

**Front View of the
MC2KW Output Module**

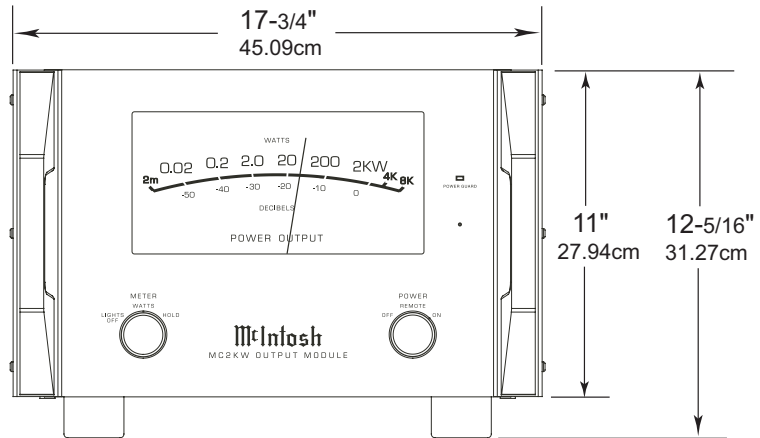

**Rear View of the
MC2KW Output Module**

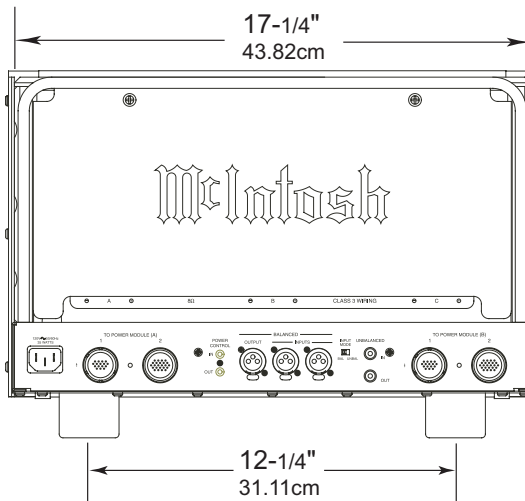

**Side View of the
MC2KW Output Module**

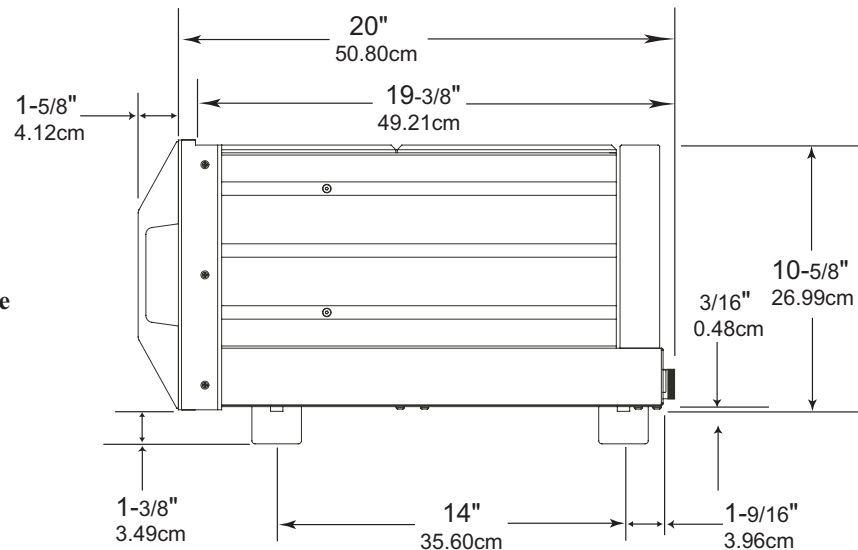

Front View of the MC2KW Power Module

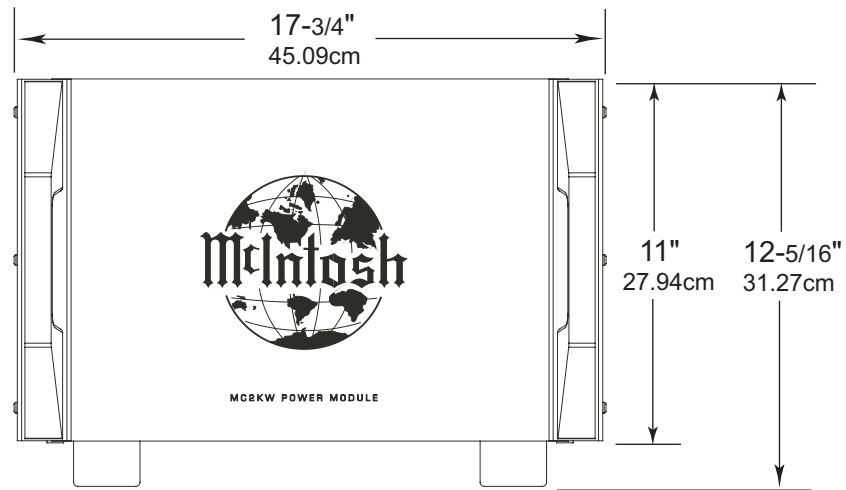

Rear View of the MC2KW Power Module

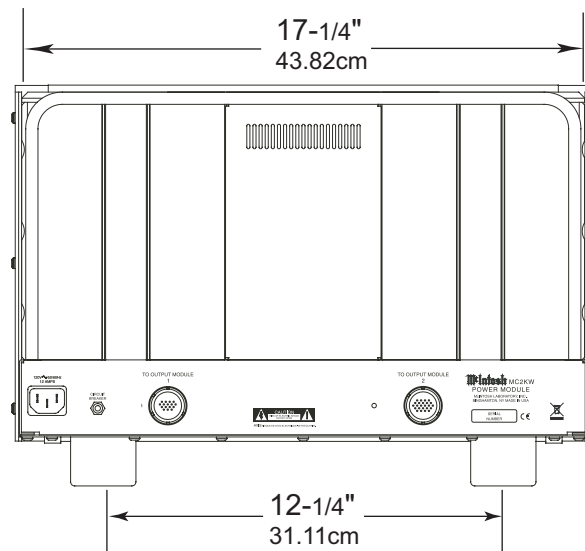

Side View of the MC2KW Power Module

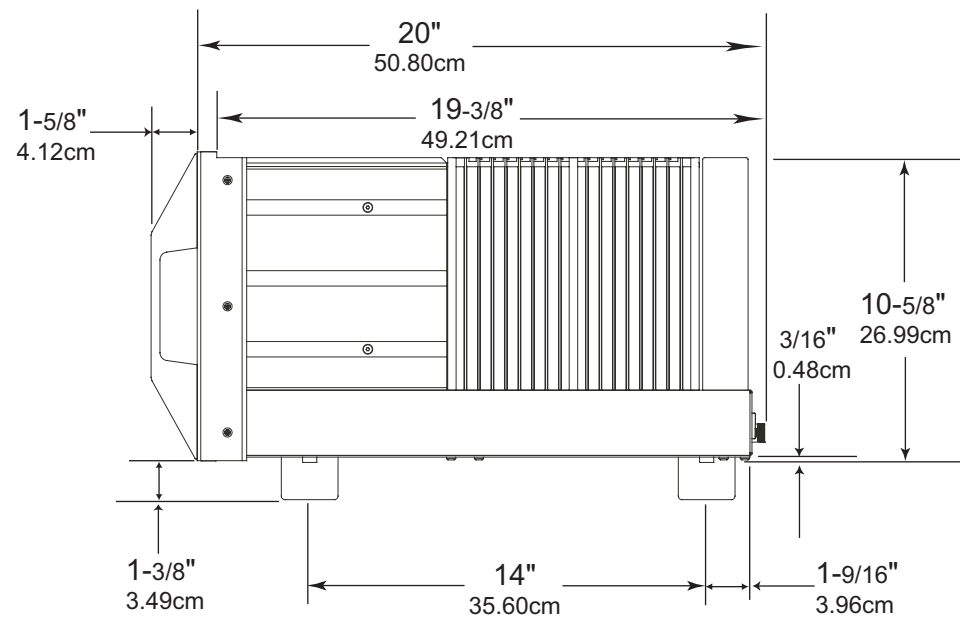

Top View of the MC2KW Output Module

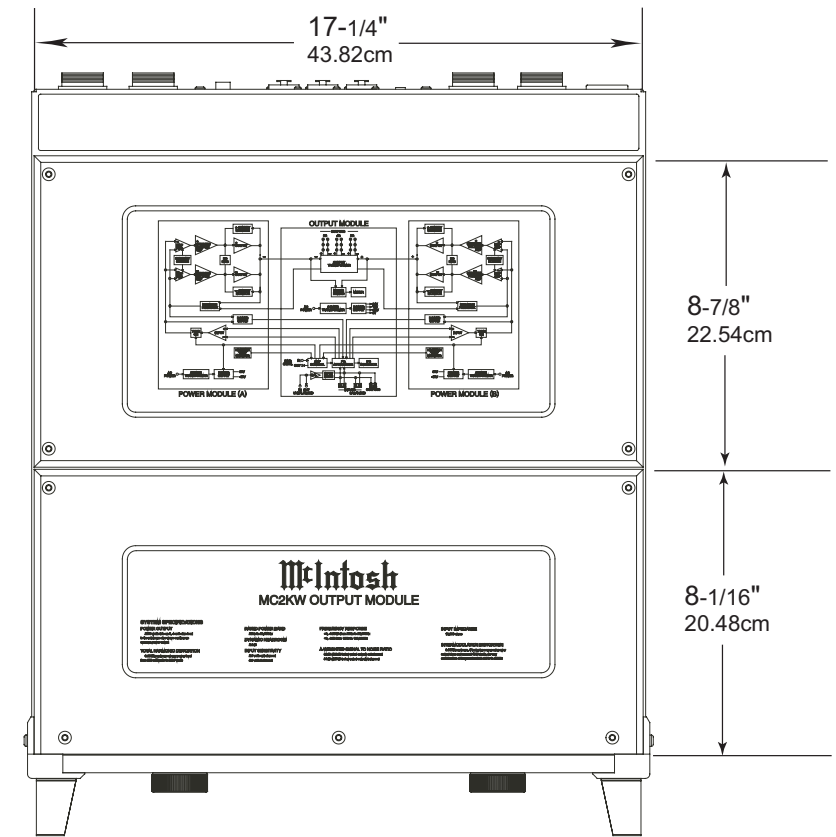

Top View of the MC2KW Power Module

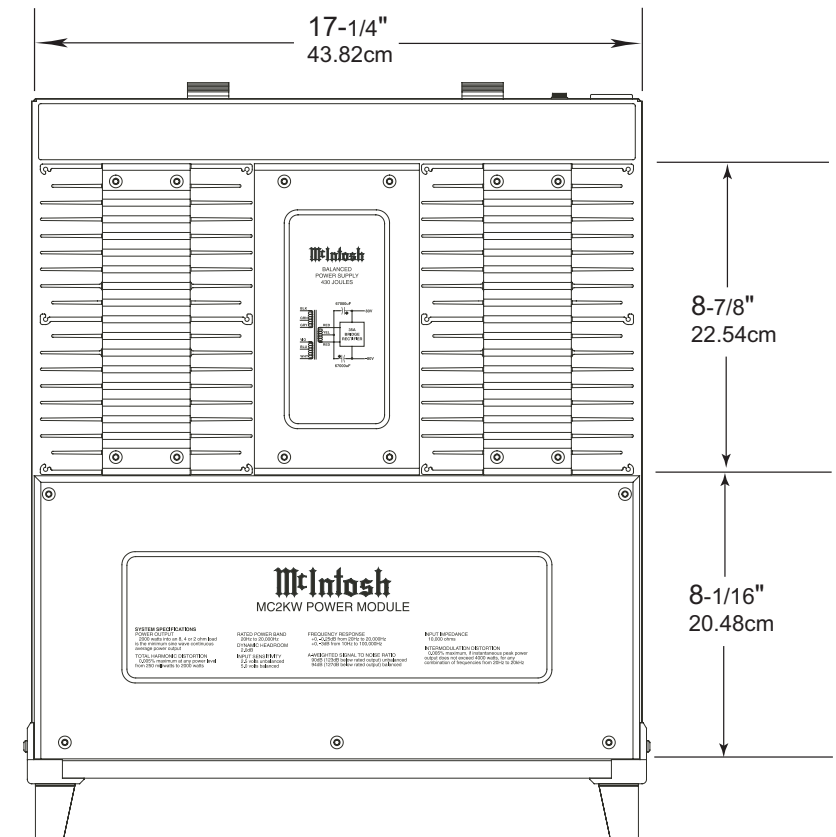

Installation

The MC2KW Output Module and MC2KW Power Modules can be placed upright on a table or shelf, standing on their four feet. If the Output Module and the two Power Modules are to be stacked vertically, the middle unit should be the Output Module. There should be at least 6 inches (15.24 cm) of space between the bottom of the upper Power Module and the top of Output Module. Likewise, there should be at least 6 inches (15.24 cm) of space between the bottom of the Output Module and the top of lower Power Module.

The four feet, may be removed from the bottom of the MC2KW Output Module and each of the MC2KW Power Modules when they are custom installed. The four feet from each unit, together with the mounting screws should be retained for possible future use if the MC2KW Output Module and MC2KW Power Modules are removed from a custom installation and used free standing again. They also can be custom installed in a piece of furniture or cabinet of your choice. The required panel cutout, ventilation cutout and unit dimensions are shown.

Always provide adequate ventilation for the MC2KW Output Module and MC2KW Power Modules. Cool operation ensures the longest possible operating life for any electronic instrument. Do not install the units directly above a heat generating component such as other high powered amplifiers. If all the components are installed in a single cabinet, a quiet running ventilation fan can be a definite asset in maintaining all the system components at the coolest possible operating temperature.

A custom cabinet installation should provide the following minimum spacing dimensions for cool operation. For the MC2KW Output Module allow at least 2 inches (5.08 cm) above the top, 2 inches (5.08cm) below the bottom and 1 inch (2.54 cm) on each side, so that airflow is not obstructed. The air spaces for the MC2KW Power Module include at least 6 inches (15.24cm) above the top, 2 inches (5.08cm) below the bottom and 2 inches (5.08cm) on each side, so that airflow is not obstructed. Allow 25 inches (63.5cm) depth behind the front panel¹ for Interconnect Cables. Allow 1 inch (2.54 cm) in front of the mounting panel for clearance. When the MC2KW Output Module and MC2KW Power Modules are to be installed in custom cabi-

nets refer to illustrations to the right. Be sure to cut out a ventilation hole in the mounting shelf according to the dimensions in the drawing.

If the custom cabinet is to be an enclosed design ventilation fans located in the bottom of the cabinet (for cool air flow input) and fans located in the top of the cabinet (for warm air flow removal) are required. The ventilaton fans should be capable of an airflow minimum of 100 Cubic Feet per Minute.

¹ Interconnect Cables are supplied with the MC2KW Power Amplifier. They are used to connect to the MC2KW Output Module with the two MC2KW Power Modules.

**MC2KW Power Module
Front Panel Custom
Cabinet Cutout**

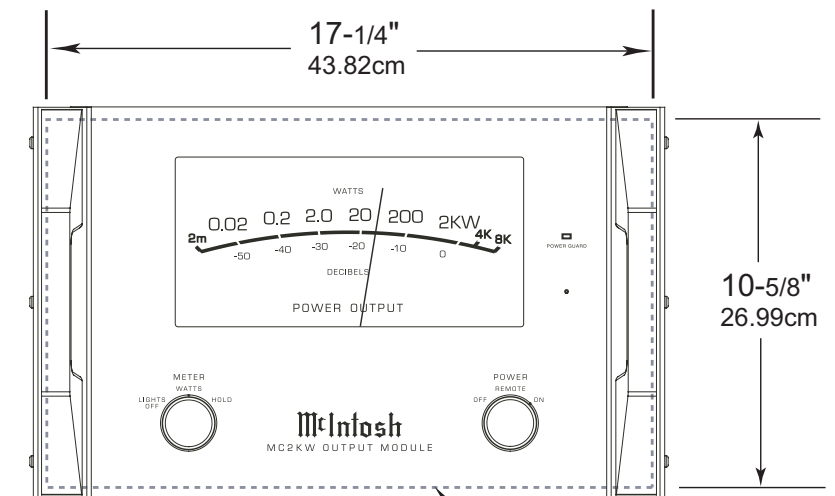

**MC2KW Power Module
Side View in Custom
Cabinet**

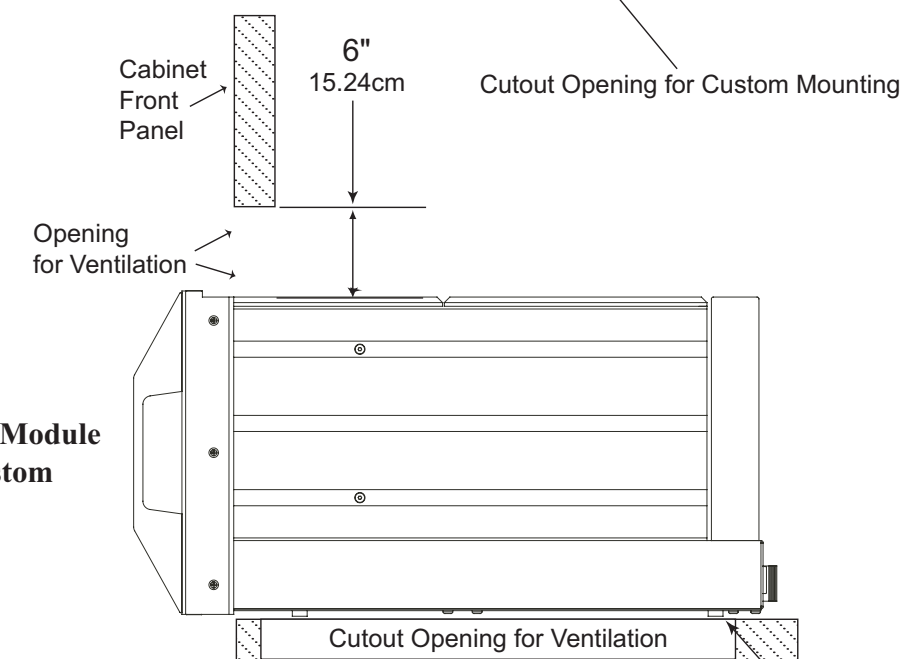

**MC2KW Power Module
Bottom View in Custom
Cabinet**

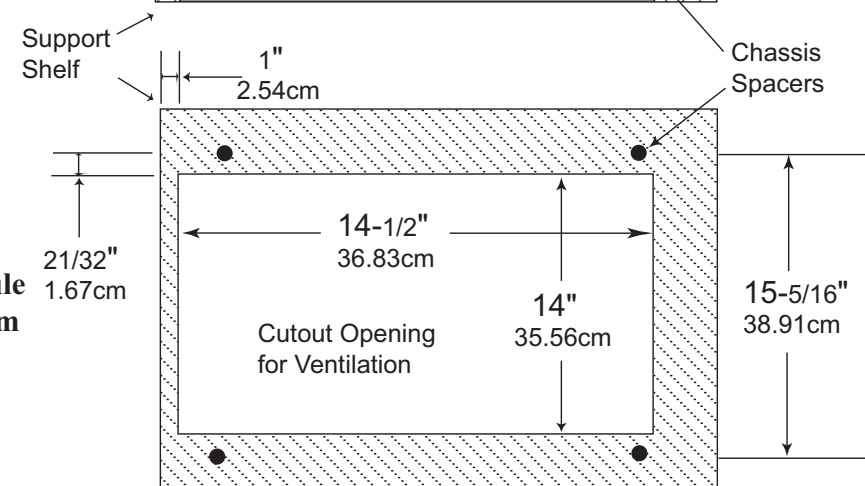

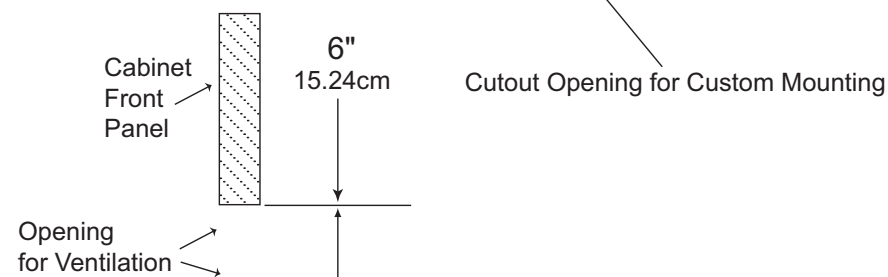
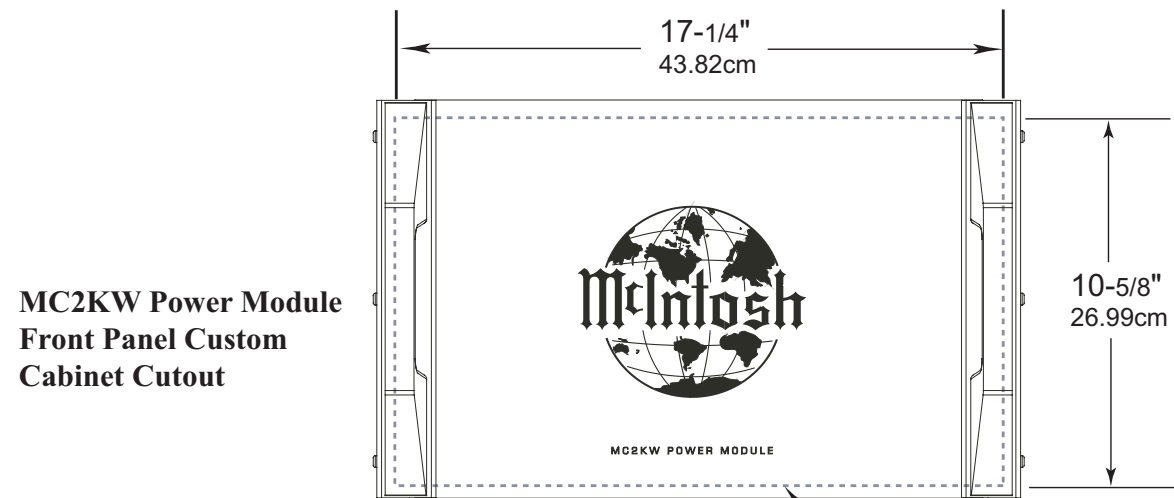

MC2KW Power Module Side View in Custom Cabinet

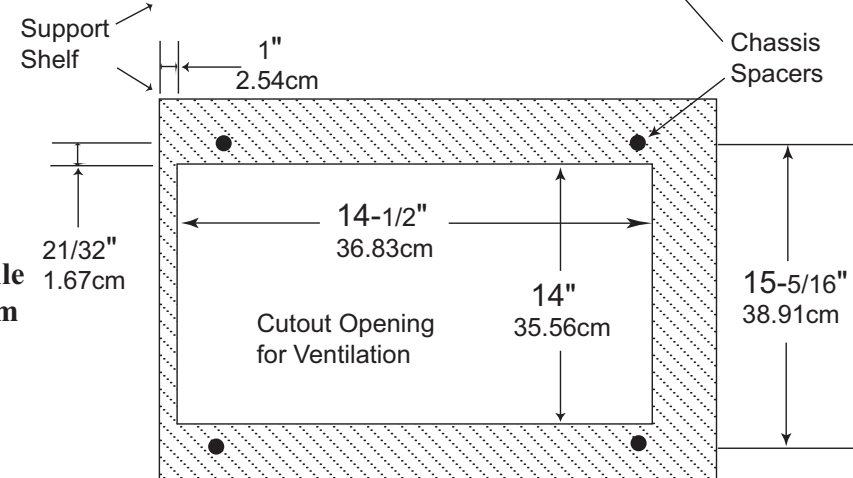
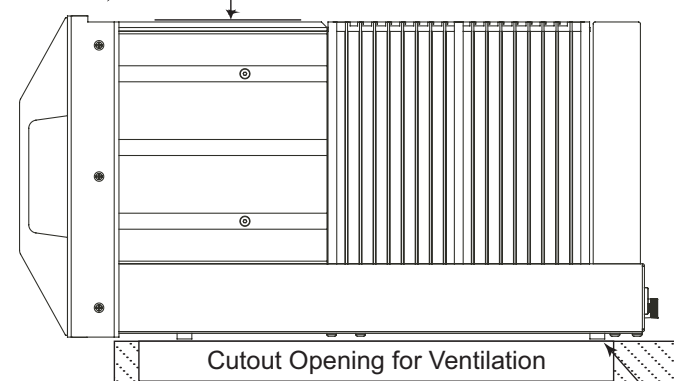

MC2KW Power Module Bottom View in Custom Cabinet

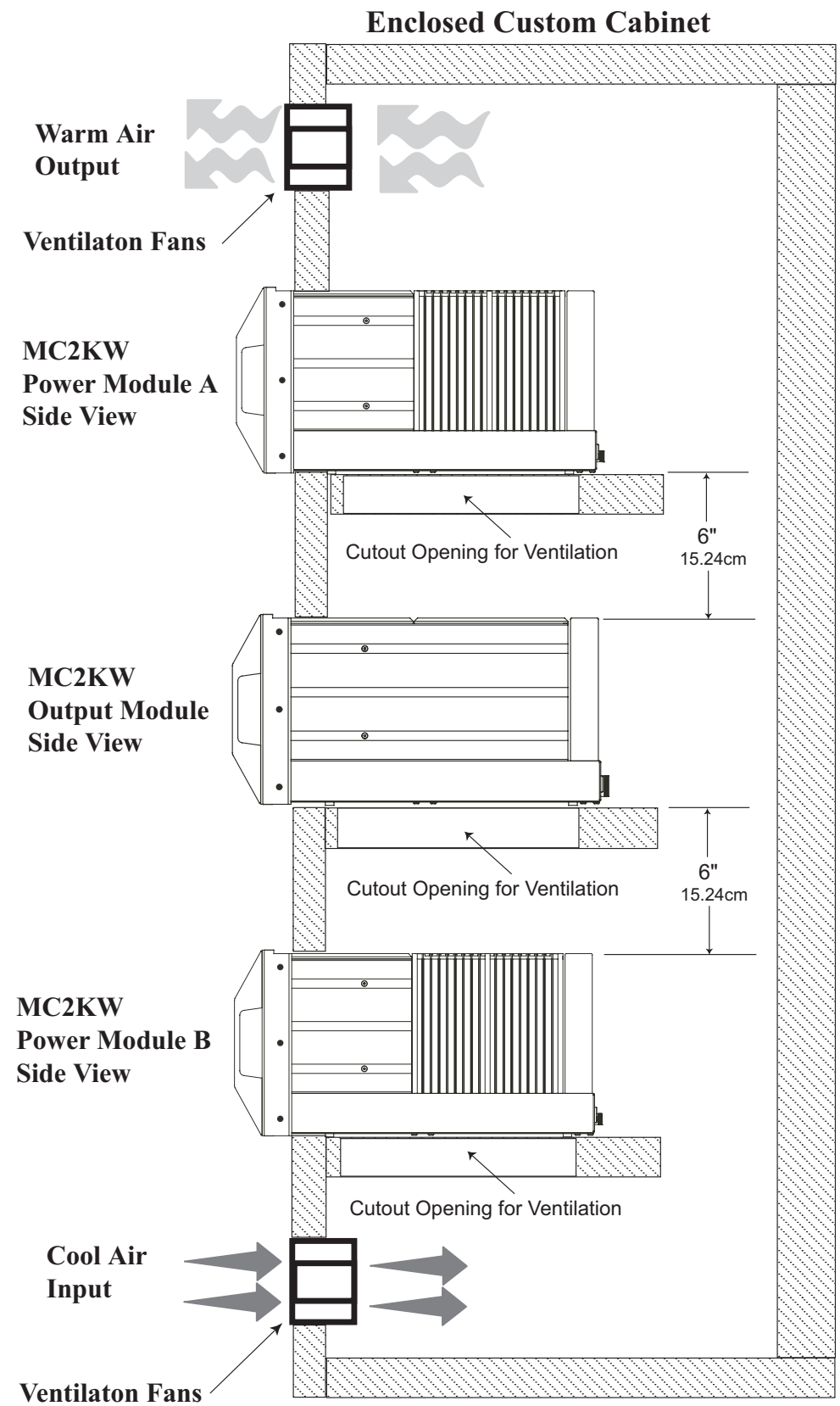

Note: The Ventilaton Fans should be capable of an Airflow minimum of 100 Cubic Feet per Minute.

Main Fuse holder, refer to information on the back panel of the MC2KW Output Module to determine the correct fuse size and rating

Connect the MC2KW Output Module Power Cord to a separate live AC outlet. Refer to information on the back panel of the MC2KW Output Module to determine the correct voltage for your unit

MC2KW OUTPUT MODULE (A) Connector 1 accepts the custom McIntosh 16 Conductor Cable. This cable attaches to the MC2KW POWER MODULE (A) Connector 1. It connects the positive power output signal from the MC2KW POWER MODULE to the Autoformer inside the MC2KW OUTPUT MODULE

MC2KW OUTPUT MODULE (A) Connector 2 accepts the custom McIntosh 21 Conductor Cable. This cable attaches to the MC2KW POWER MODULE (A) Connector 2. It connects the positive input signal, control and power supply voltages to the MC2KW POWER MODULE

POWER CONTROL IN receives a turn On/Off Trigger from a McIntosh component. POWER CONTROL OUT sends a turn On/Off Trigger to the next McIntosh component

BALANCED INPUTS for audio cables from a preamplifier or control center audio output. BALANCED OUTPUT to provide signal for the next Power Amplifier

INPUT MODE switch selects BALANCED or UNBALANCED Inputs

UNBALANCED INPUT for an audio cable from a preamplifier or control center audio output. UNBALANCED OUTPUT provides the input signal for the next Power Amplifier

MC2KW OUTPUT MODULE (B) Connector 1 accepts the custom McIntosh 16 Conductor Cable. This cable attaches to the MC2KW POWER MODULE (B) Connector 1. It connects the negative power output signal from the MC2KW POWER MODULE to the Autoformer inside the MC2KW OUTPUT MODULE

MC2KW OUTPUT MODULE (B) Connector 2 accepts the custom McIntosh 21 Conductor Cable. This cable attaches to the MC2KW POWER MODULE (B) Connector 2. It connects the negative input signal, control and power supply voltages to the MC2KW POWER MODULE

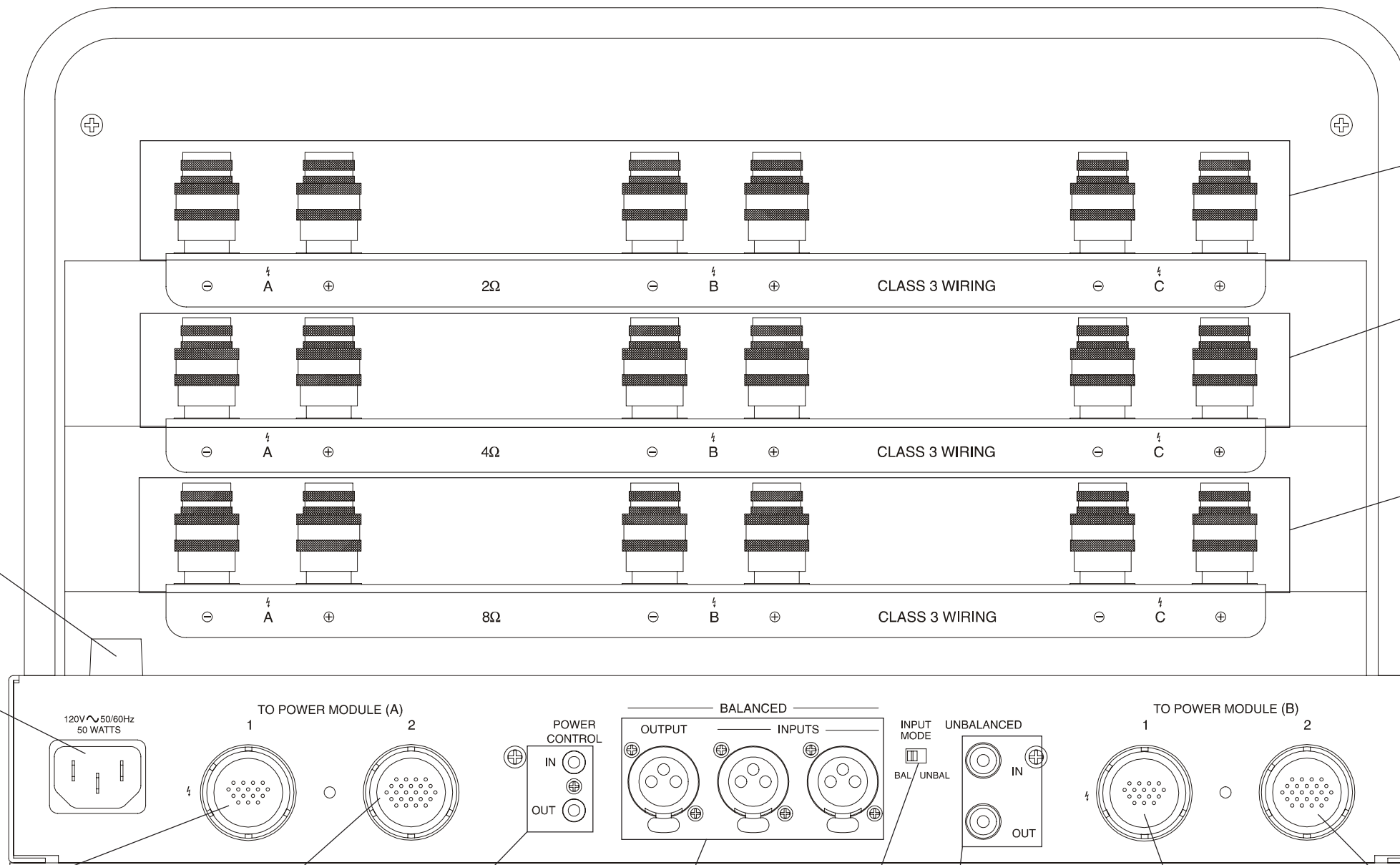

OUTPUT Connections A, B, and C for a 2 ohm Loudspeaker

OUTPUT Connections A, B, and C for a 4 ohm Loudspeaker

OUTPUT Connections A, B, and C for a 8 ohm Loudspeaker

Caution: The Loudspeaker \ominus Negative Connections for each impedance (2, 4 and 8 ohms) are above chassis ground. Do not combine any connections together, ground them or connect with another MC2KW Power Amplifier or any other Power Amplifier.

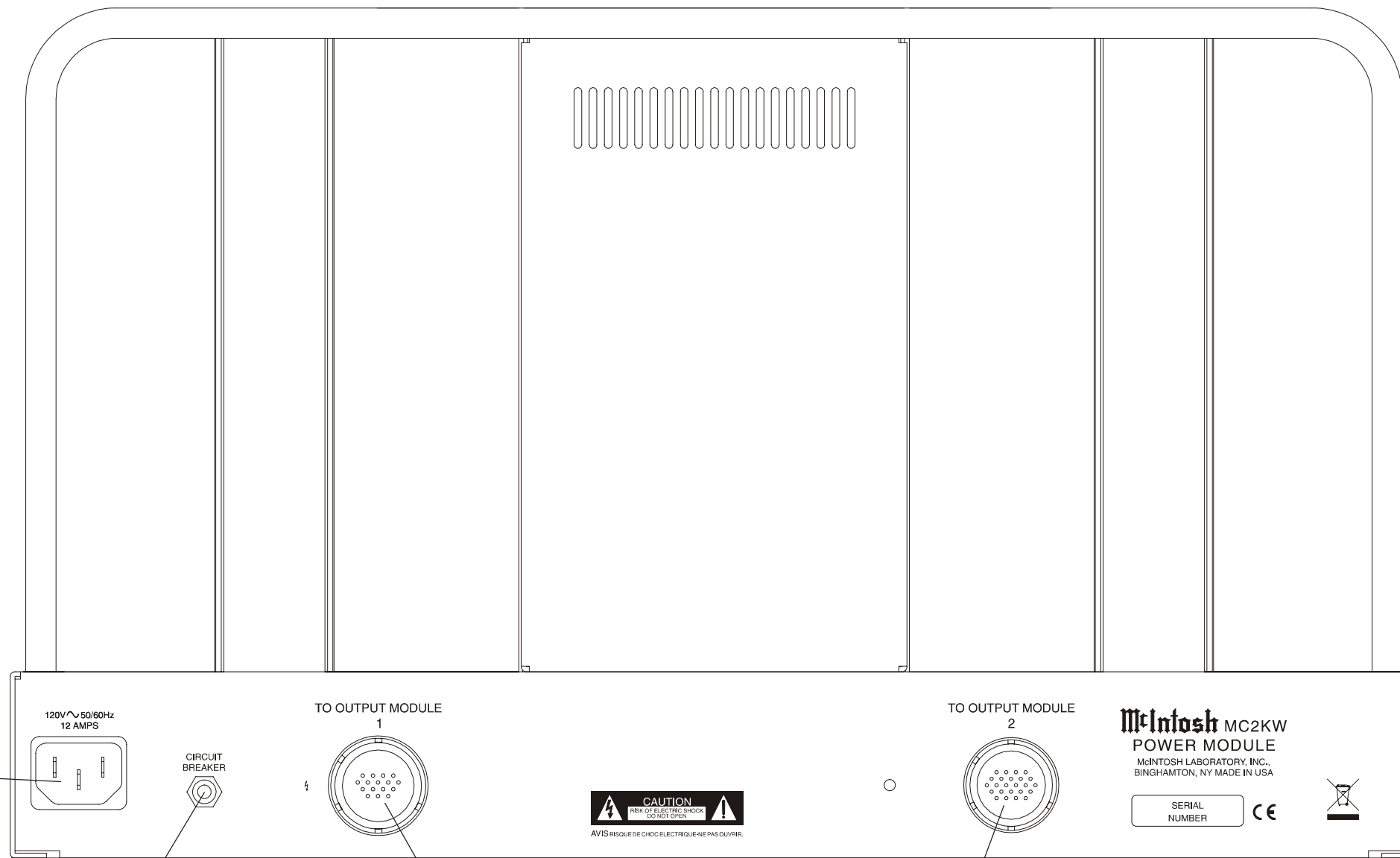

Connect the MC2KW Power Module power cord to a dedicated live AC Circuit with Outlet¹. Refer to information on the back panel of the MC2KW Power Module to determine the correct voltage for your unit.

CIRCUIT BREAKER
Press to reset if the MC2KW Power Module will not power up

MC2KW POWER MODULE (A or B)²
Connector 1 accepts the custom McIntosh 16 Conductor Cable. This cable attaches to the MC2KW OUTPUT MODULE (A or B)² Connector 1. It connects the power output signal of the MC2KW POWER MODULE to the Autoformer inside the MC2KW OUTPUT MODULE.

MC2KW OUTPUT MODULE (A or B)²
Connector 2 accepts the custom McIntosh 21 Conductor Cable. This cable attaches to the MC2KW OUTPUT MODULE (A or B)² Connector 2. It connects the input signal, control and power supply voltages from the MC2KW OUTPUT MODULE.

² A MC2KW Power Amplifier consists of one MC2KW Output Module and two MC2KW Power Modules. The first MC2KW Power Module is referred to as chassis "A" and the second MC2KW Power Module is referred to as chassis "B". Both MC2KW Power Modules "A" and "B" connect to the same MC2KW Output Module.

¹ Each of the MC2KW Power Modules needs to be connected to a dedicated AC Circuit with Outlet. Refer to "Important Information" note 5 on page 4 in this Owner's Manual for additional information.



How to Connect the MC2KW Output Module/Power Modules together; Power Control and Audio connections

These two pages contain information for connecting together the McIntosh MC2KW Output Module and the MC2KW Power Modules; and that combination to the C1000 Preamplifier.

McIntosh's Power Control connections allows for unified audio system operations, one push-button to switch the entire system On or Off. The following steps also include connections from the C1000's Right Channel Main Audio Output to the MC2KW Power Amplifier (Right Channel). The second MC2KW Power Amplifier (Left Channel) Audio is connected in a similar manner.

1. Connect one of the supplied custom 16 Conductor Cables from the MC2KW Output Module TO POWER MODULE (A) Connector 1 to the MC2KW Power Module (A) Connector 1.

Note: After the cable connector is firmly seated into the chassis socket, rotate the locking collar clockwise until it is tight (do not over tighten).

2. In a similar manner, connect the supplied custom 21 Conductor Cable from the MC2KW Output Module TO POWER MODULE (A) Connector 2 to the MC2KW Power Module (A) Connector 2.
3. Connect the remaining custom 16 Conductor Cable from the MC2KW Output Module TO POWER MODULE (B) Connector 1 to the MC2KW Power Module (B) Connector 1.
4. In a similar manner, connect the remaining custom 21 Conductor Cable from the MC2KW Output Module TO POWER MODULE (B) Connector 2 to the MC2KW Power Module (B) Connector 2.

5. Connect a Power Control Cable from the C1000C Power Control Main Jack to the POWER CONTROL IN Jack on the McIntosh MC2KW Output Module (Right Channel). Then connect another Power Control Cable from the McIntosh MC2KW Output Module (Right Channel) POWER CONTROL OUT Jack to the McIntosh MC2KW OUTPUT MODULE (Left Channel) POWER CONTROL IN In Jack.

Note: There is approximately a one-half second delay added to the Power Control Output Jack voltage in McIntosh Power

Amplifiers to reduce the strain on the AC Power Line. This will delay the Turn-On of the second McIntosh Power Amplifier (left channel in this system). If there are additional McIntosh Power Amplifiers in the system, connect the POWER CONTROL OUT Jack of the MC2KW OUTPUT MODULE (Left Channel) to the Power Control In on the next Power Amplifier.

6. Connect a XLR Cable from the C1000 Preamplifier or Tube Preamplifier Main Right Output Balanced, to one of the Balanced Inputs on MC2KW Output Module (Right Channel).

Note: Unbalanced Inputs and Outputs may optionally be used.

7. Place the INPUT MODE Switch on the Rear Panel of the MC2KW Output Module to the BALANCED position if Balanced Connections were utilized in step 6. If Unbalanced Connections are used place the switch in the UNBALANCED position.

8. In a similar manner, connect a XLR Cable from the C1000 Preamplifier or Tube Preamplifier Main Left Output Balanced, to one of the Balanced Inputs on the MC2KW Output Module (Left Channel).

Note: If both C1000P and C1000T Preamplifiers are used in the system, the C1000 Tube Preamplifier Main Right Output Balanced connects to the remaining Balanced Input on MC2KW Output Module; the Left Channel is connected in a similar manner.

9. Proceed to page 14 for the connection of Loudspeaker(s) to the MC2KW Power Amplifier.

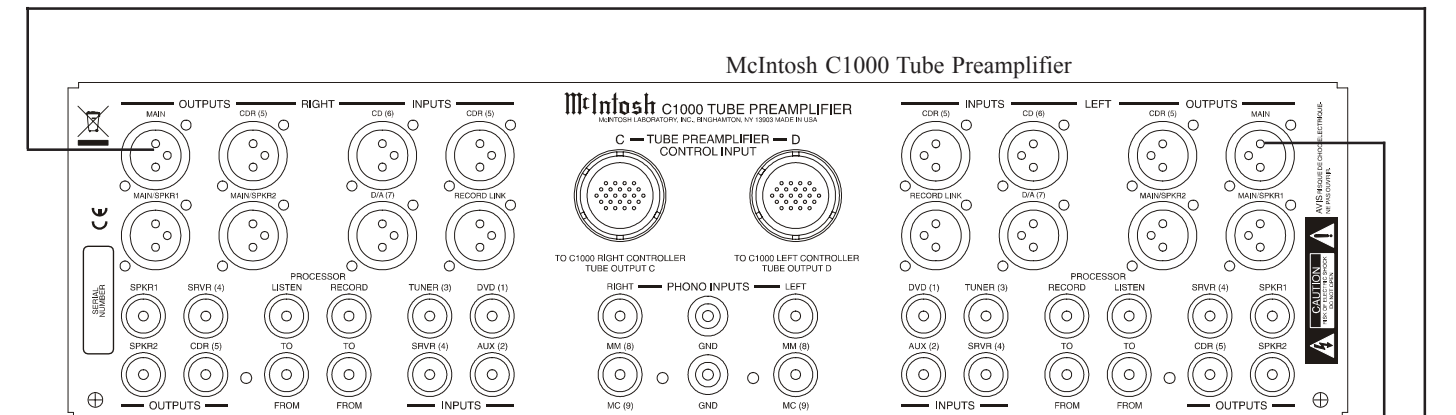

Connect to second MC2KW Output Module (Left Channel)

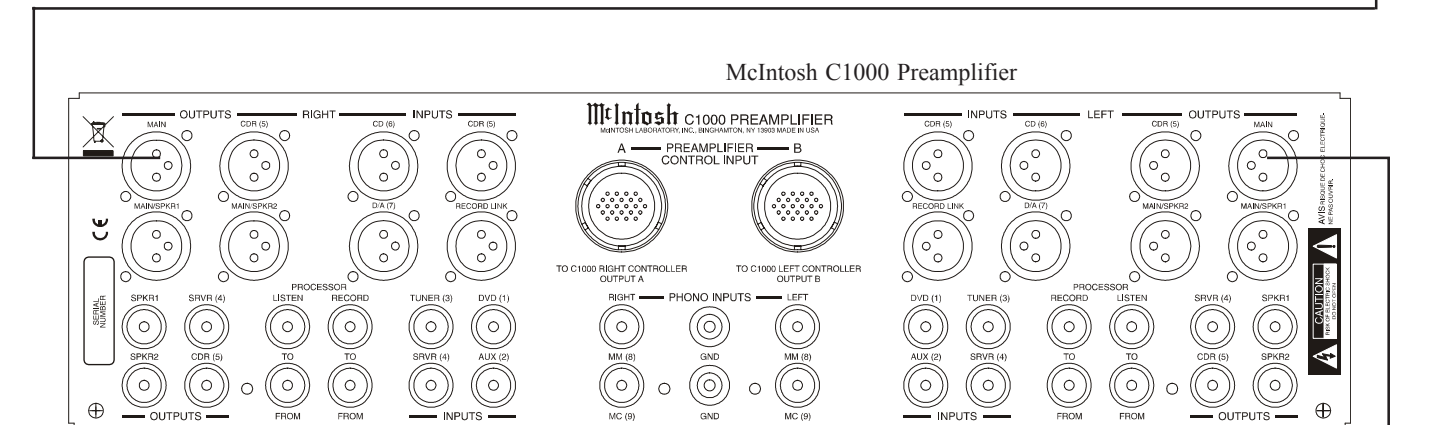
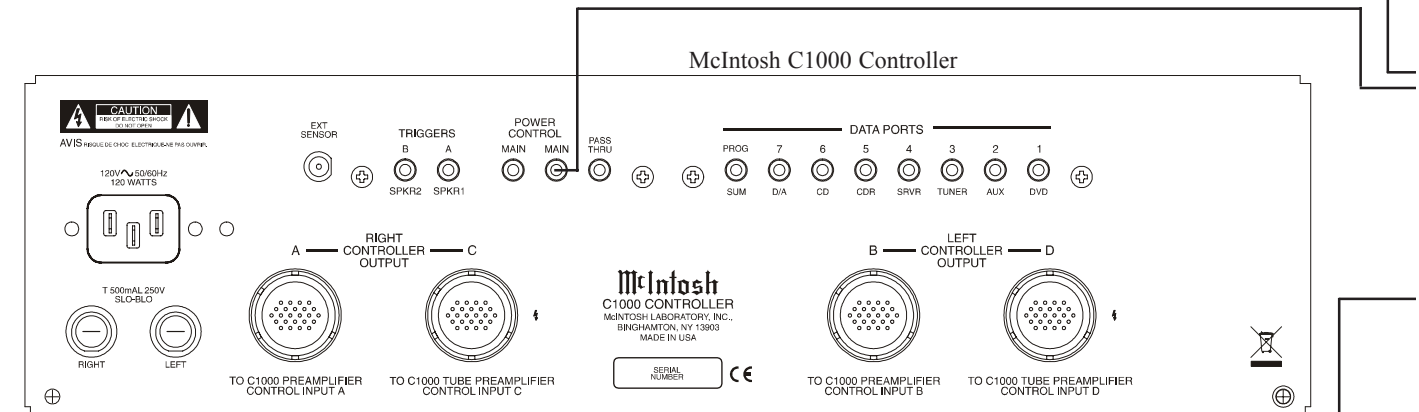

Connect to second MC2KW Output Module (Left Channel)

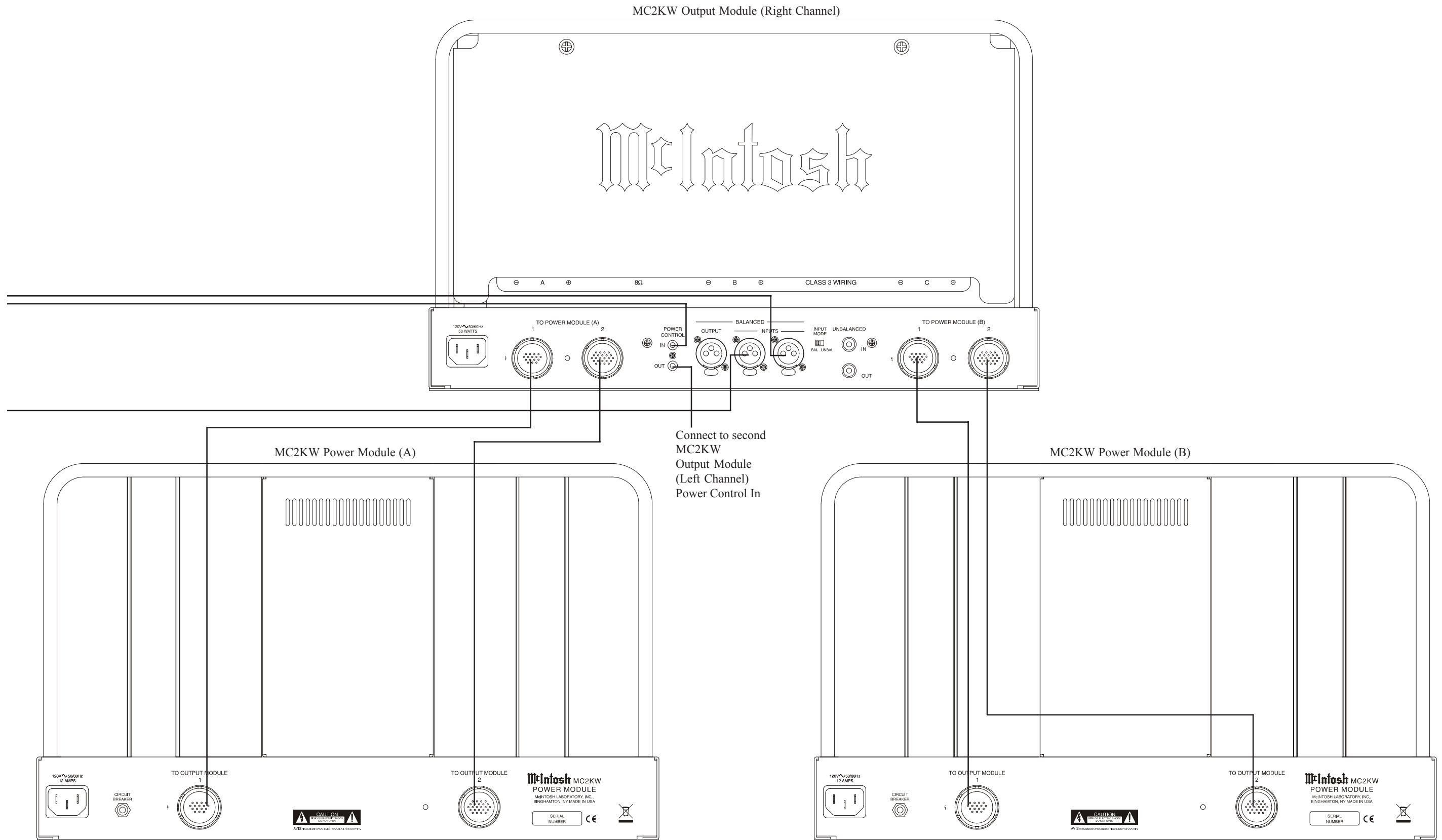

How to Connect the MC2KW Output Module to Loudspeakers

Caution: The supplied AC Power Cords should not be connected to the Rear Panel of the MC2KW Output Module and both of the Power Modules until after the Loudspeaker Connections have been made and the supplied protective Terminal Connections Cover has been installed. Failure to observe this could result in Electric Shock.

- Using the supplied “T” shaped tool, remove the two screws from the Rear Cover on the MC2KW Output Module and remove the cover. Place the cover and screws in a safe location. Refer to figures 9 and 10.

Note: The MC2KW Output Module Removable Covers consist of a Rear piece and Top piece. In certain installations the removal of the Top Cover in addition to the Rear Cover might provide easier access to the Output Connection Terminals, refer to figures 9, 10 and 11.

- Prepare the Loudspeaker Hookup Cables that attach to the MC2KW Output Module by choosing one of the methods below:

Note: Refer to page 4 “Important Information” note 3 for cable size.

Bare wire cable ends:

Carefully remove sufficient insulation from the cable ends, refer to figures 1, 2 & 3. If the cable is stranded, carefully twist the strands together as tightly as possible.

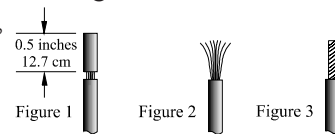

Note: If desired, the twisted ends can be tinned with solder to keep the strands together, or attach spade lug and/or banana connector.

Spade lug or prepared wire connection:

Insert the spade lug connector or prepared section of the cable end into the terminal side access hole, and tighten the terminal cap until the cable is firmly clamped into the terminal so the wires cannot slip out. Refer to figures 4, 5 & 6.

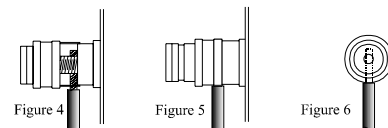

Banana plug connection:

Insert the banana plug into the hole at the top of the terminal. Tighten the top portion of the terminal post to secure the banana plug in place. Refer to figures 7 and 8.

Note: The use of Banana Plugs is for use in the United States and Canada only.

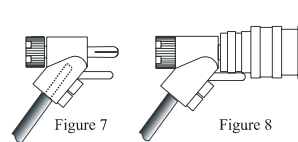

- For each of three output impedances there are three sets of identical connection terminals (A, B and C). This facilitates tri-cabling of Loudspeaker Connections to the MC2KW Output Module.
- Connect the Loudspeaker hookup cables to the output terminals that match the impedance of the Loudspeaker, being careful to observe the correct polarities. Output impedance connections of 2 ohms, 4 ohms and 8 ohms are provided. If the Loudspeaker’s impedance is in-between the available connections, use the nearest lower impedance connection.

WARNING: Loudspeaker terminals are hazardous live and present a risk of electric shock. For additional instruction on making Loudspeaker Connections contact your McIntosh Dealer or McIntosh Technical Support.

- Re-attach the previously removed Cover(s) making sure to route the Loudspeaker Cables between the top of the Stainless Steel Chassis and underneath the bottom Rear Cover. Refer to figure 9.
- Connect the AC Power Cords to each of the MC2KW Power Modules and connect the plug end of each cord to dedicated active AC outlets. Connect the remaining AC Power Cord to the MC2KW Output Module and connect the plug end of the cord to a separate active AC outlet. Refer to page 4 “Important Information” note 5 for AC Outlet. Refer to page 4 “Important Information” note 5 for AC Power requirements.

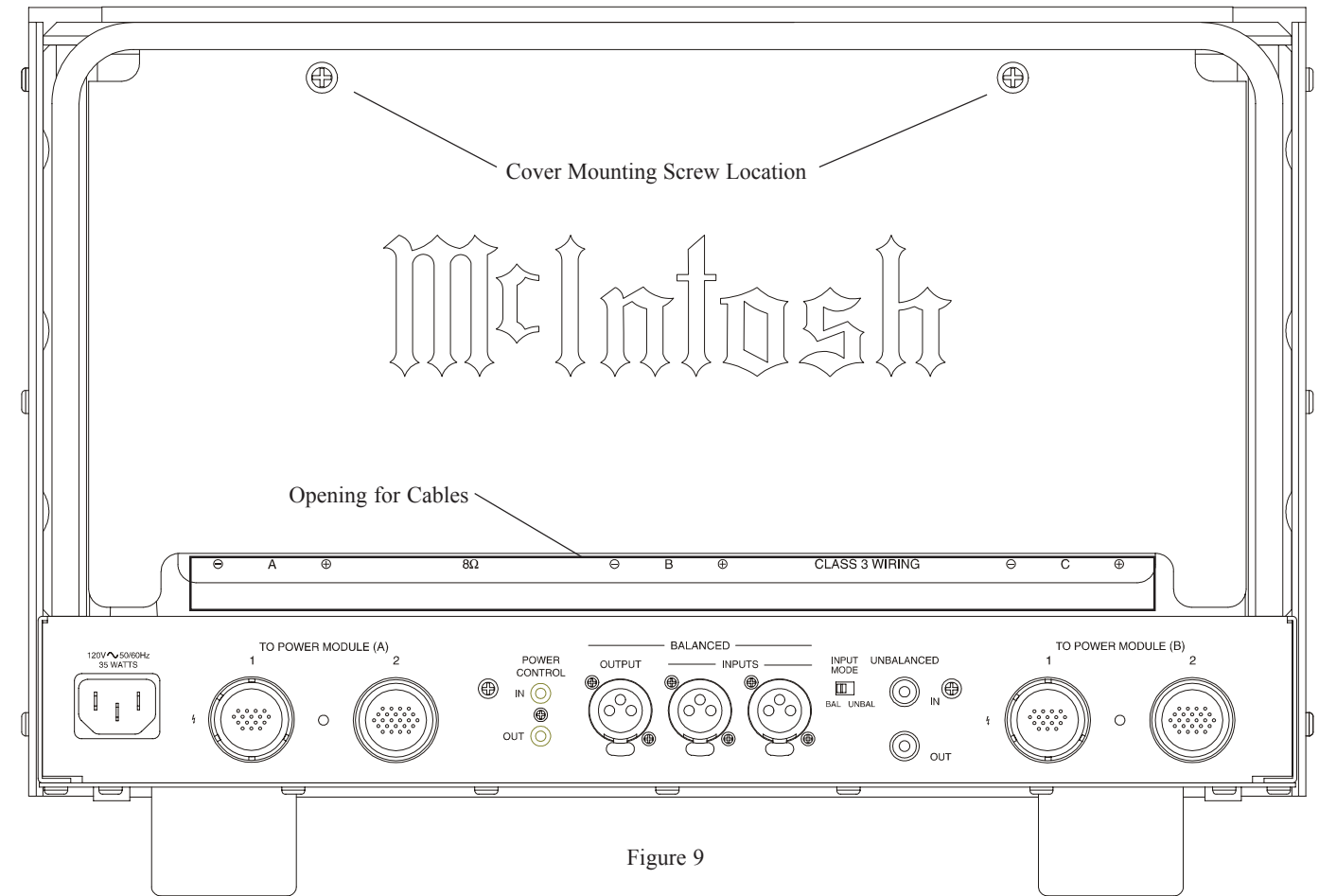

Figure 9

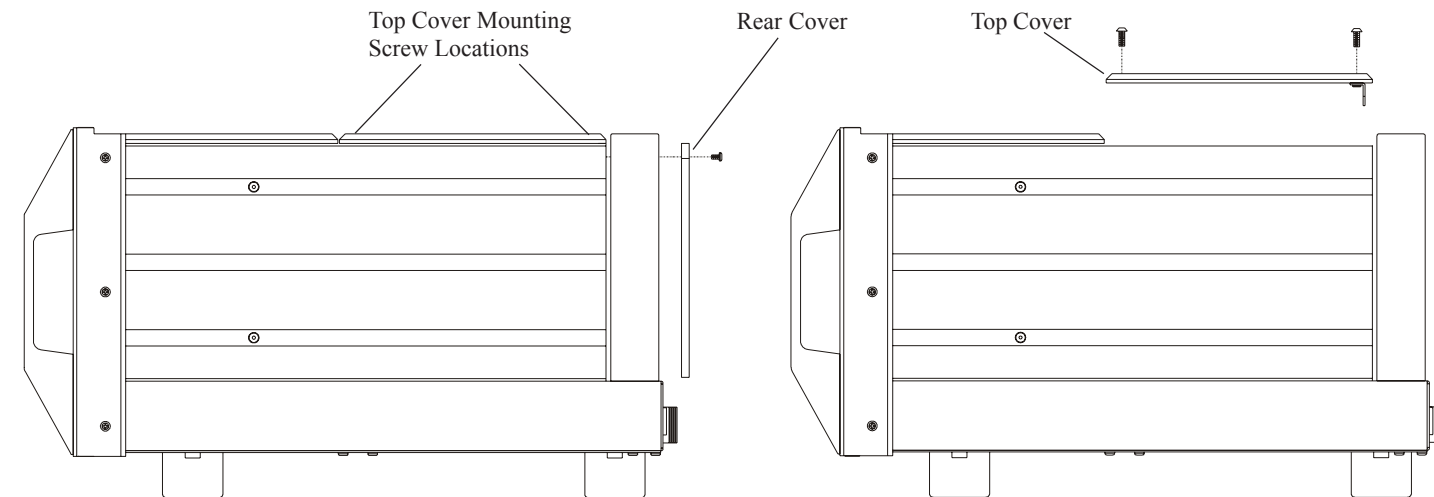
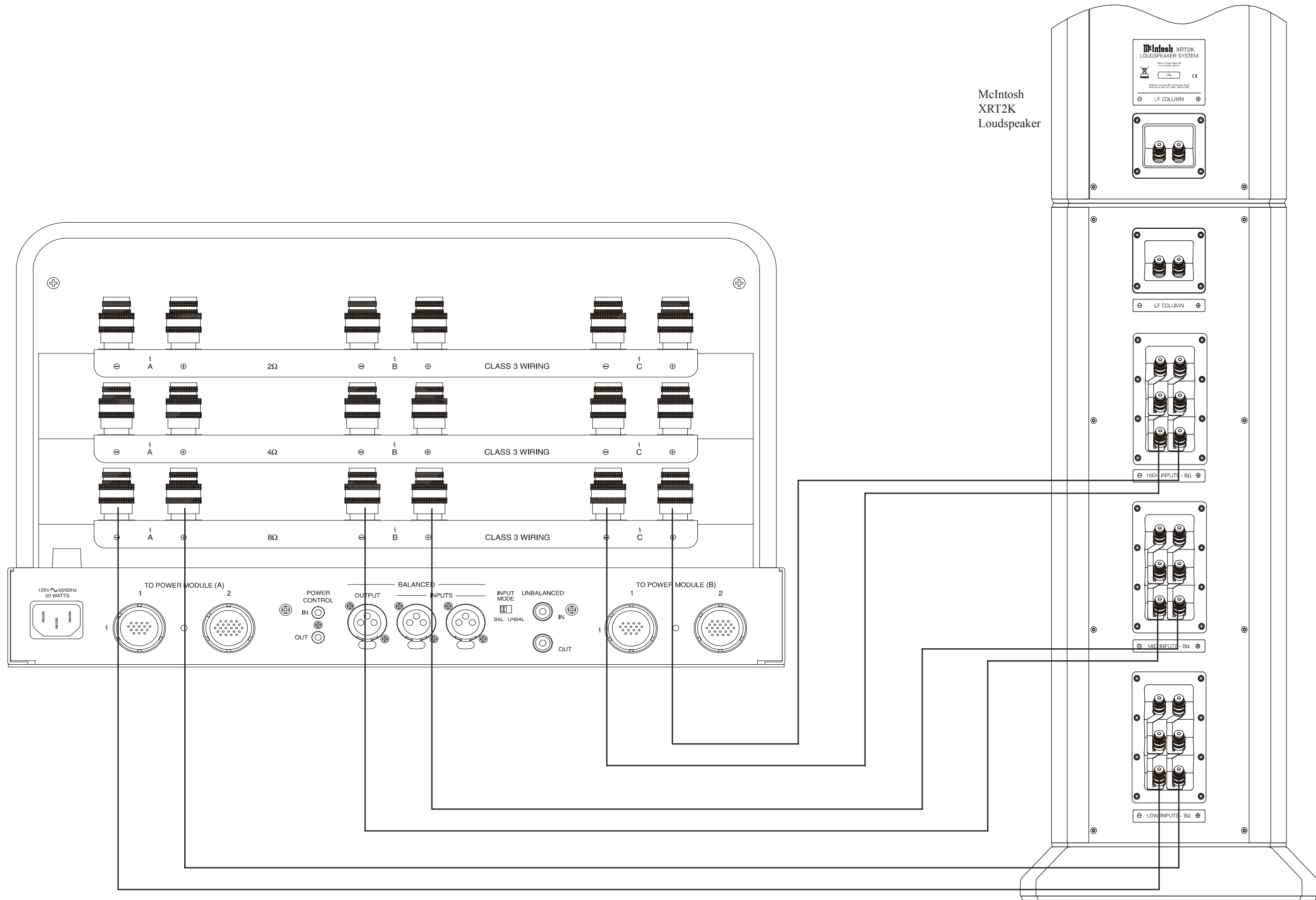
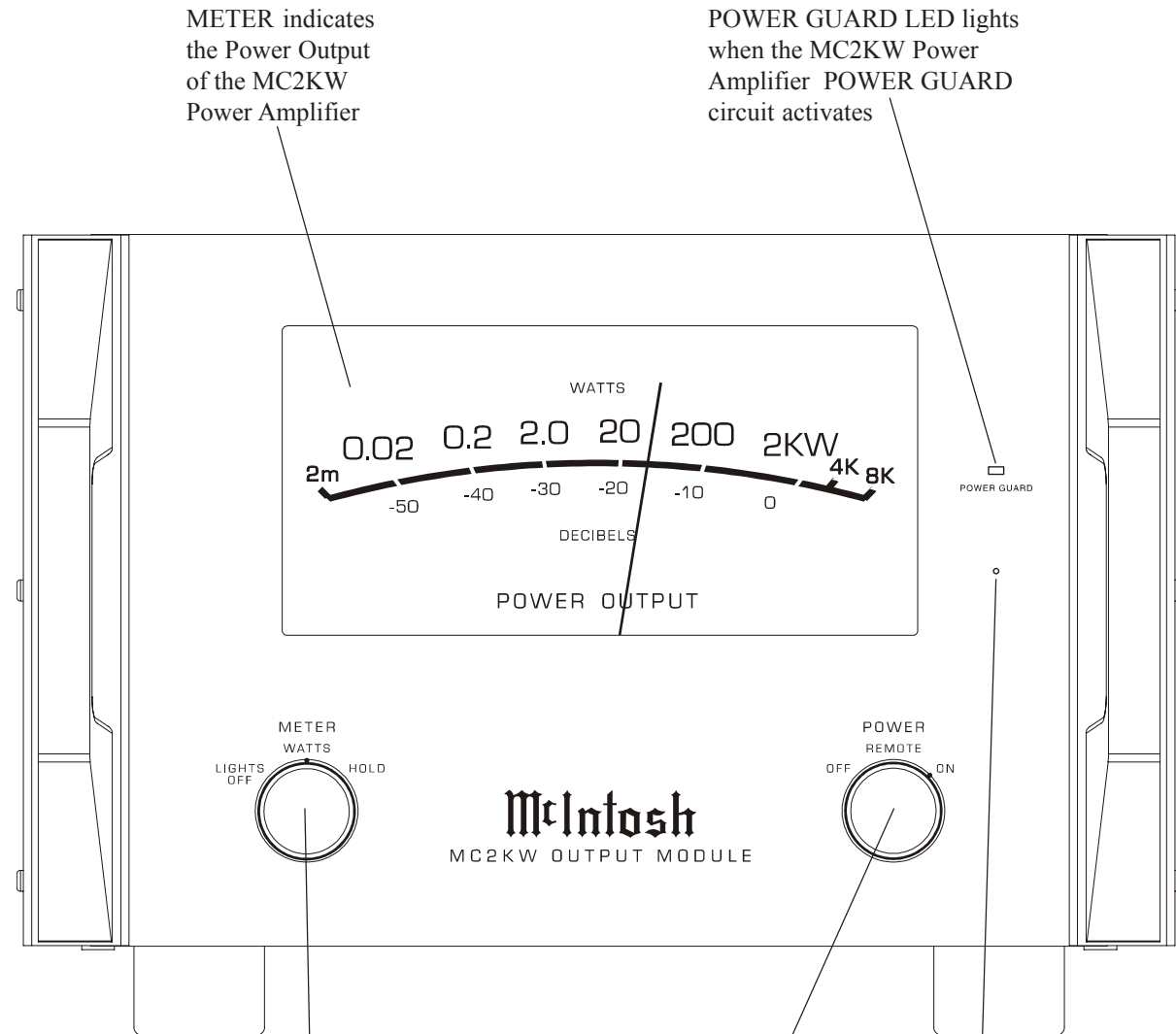

Figure 10

Figure 11



McIntosh
XRT2K
Loudspeaker



METER indicates the Power Output of the MC2KW Power Amplifier

POWER GUARD LED lights when the MC2KW Power Amplifier POWER GUARD circuit activates

METER SWITCH
LIGHTS OFF WATTS HOLD

POWER SWITCH
OFF REMOTE ON

POWER GUARD

McIntosh
MC2KW OUTPUT MODULE

METER Switch selects the display modes of the Power Output Meter

Pilot Light Indicates when the MC2KW Output Module is connected to AC Power

POWER Switch turns the MC2KW Power Amplifier Off, Remote (On/Off) or On

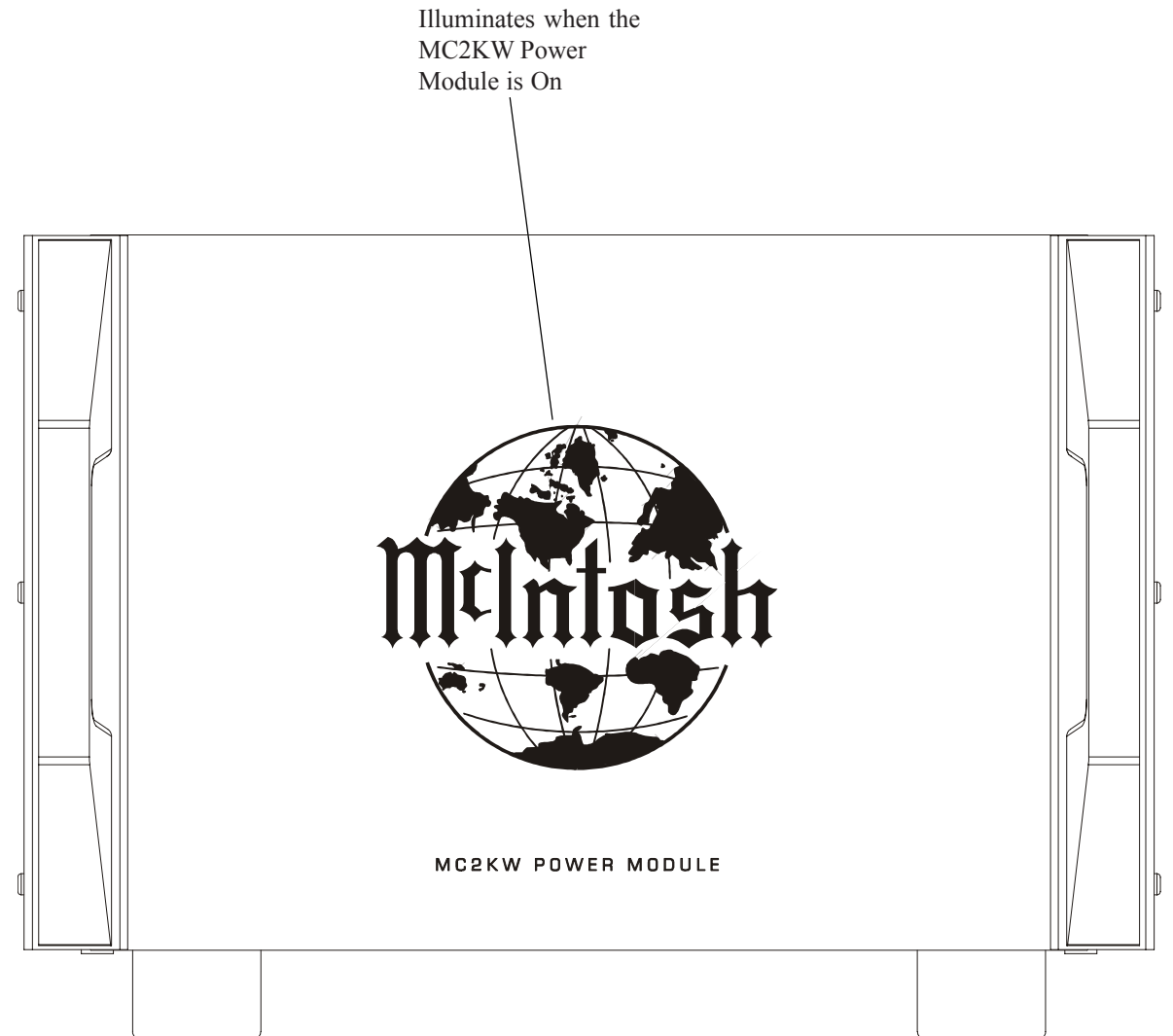

Illuminates when the MC2KW Power Module is On



MC2KW POWER MODULE

How to Operate the MC2KW Power Amplifier

Power On

With the POWER Switch set to the REMOTE Position, the MC2KW Power Amplifier will turn On or Off when a McIntosh Preamplifier or A/V Control Center switches On or Off. For manual operation, rotate the POWER Switch to the ON or OFF Position as desired. Refer to figure 12.

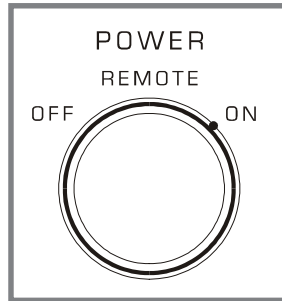

Figure 12

Notes: 1. There must be a power control connection between the MC2KW OUTPUT MODULE and the McIntosh

Preamplifier or A/V Control Center in order for the remote power turn-on to function.

2. The MC2KW Power Modules will not switch On, with the front Panel Illuminated, unless they are connected to the MC2KW Output Module with the supplied custom hookup cables and the Output Module is switched On.

Meter Selection

Rotate the meter mode switch to select the meter operation mode desired. Refer to figures 13 and 14.

Lights Off - Meter lights are turned off and the meter will continue to indicate the power output.

Watts - The meters respond to all the musical information being produced by the amplifier. They indicate to an accuracy of at least 95% of the power output with only a single cycle of a 2000Hz tone burst.

Hold - The meter pointer is locked to the highest

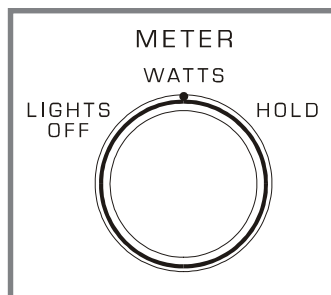

Figure 13

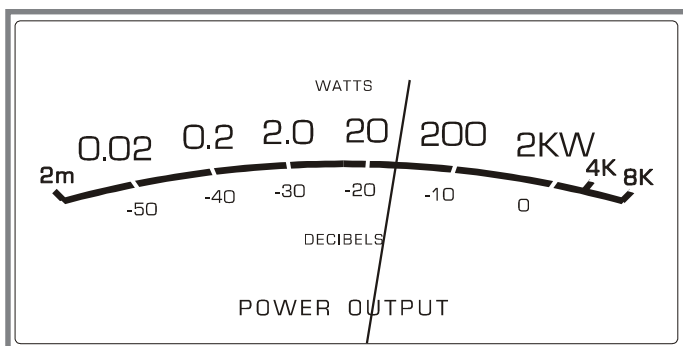

Figure 14

power peak in a sequence of peaks. It is electronically held to this power level until a higher power peak passes through the amplifier. The meter pointer will then rise to indicate the higher peak. If no further power peaks are reached, the meter pointer will very slowly return to its rest position or lower power level. The decay rate is approximately 6dB per minute.

Note: The MC2KW OUTPUT MODULE Power Output Meter indicates the actual wattage delivered to the loudspeakers by responding to the combination of current and voltage output.

Input Mode Switch

The Input Mode Switch, which is located on the Rear Panel of the MC2KW OUTPUT MODULE, allows selection of either the Balanced or Unbalanced Input. Refer to figure 15.

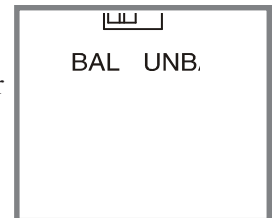

Figure 15

Pilot Light

When AC Power is applied to the MC2KW the Front Panel Pilot Light will illuminate. The Pilot Light is located about 1-1/2 inches (3.81cm) below the Power Guard Light. Refer to figure 16.

Power Guard Light

The Power Guard Light, driven by the Power Guard Circuitry, under normal conditions will only illuminate momentarily during extremely loud peaks in the music. This occurs when the MC2KW Power Amplifier is being asked to deliver a power level way beyond its rated 2,000 watt output. Refer to figure 16.

In the event that either or both MC2KW Power Modules over heat, due to improper ventilation and/or high ambient temperature, the protection circuits will activate. The sound will be muted and the MC2KW Output Module Front Panel Power Guard LED will continuously indicate ON. When the MC2KW Power Modules have returned to a safe operating temperature, normal operation will resume.

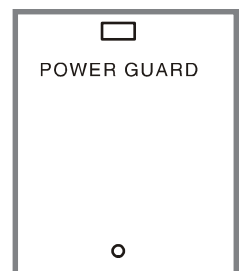

Figure 16



Technical Description

McIntosh Laboratory, the company who introduced the world's first amplifier that could be called "High Fidelity", has done it again. The McIntosh engineering staff has created a power amplifier without compromise, using the most advanced McIntosh circuit design concepts.

For the first time, the new McIntosh MC2KW Power Amplifier is capable of supplying the power required to reproduce the full dynamic range of a symphony orchestra including pipe organ. This includes driving low efficiency Loudspeakers in a large room to concert hall volume levels. It can reproduce complex music with complete accuracy,

with no added distortion or noise. The Triple Chassis Design also allows for easier placement in a room than would be possible in a single chassis design, yet with no compromise in performance or reliability.

A continuous average power output rating of 2,000 watts and with a peak output current of 200 amperes, makes this not only the most advanced, but also the most powerful amplifier McIntosh has ever manufactured. The distortion limits for the MC2KW Power Amplifier are no more than 0.005% at rated power output for all frequencies from 20Hz to 20,000Hz. Typical performance at mid fre-

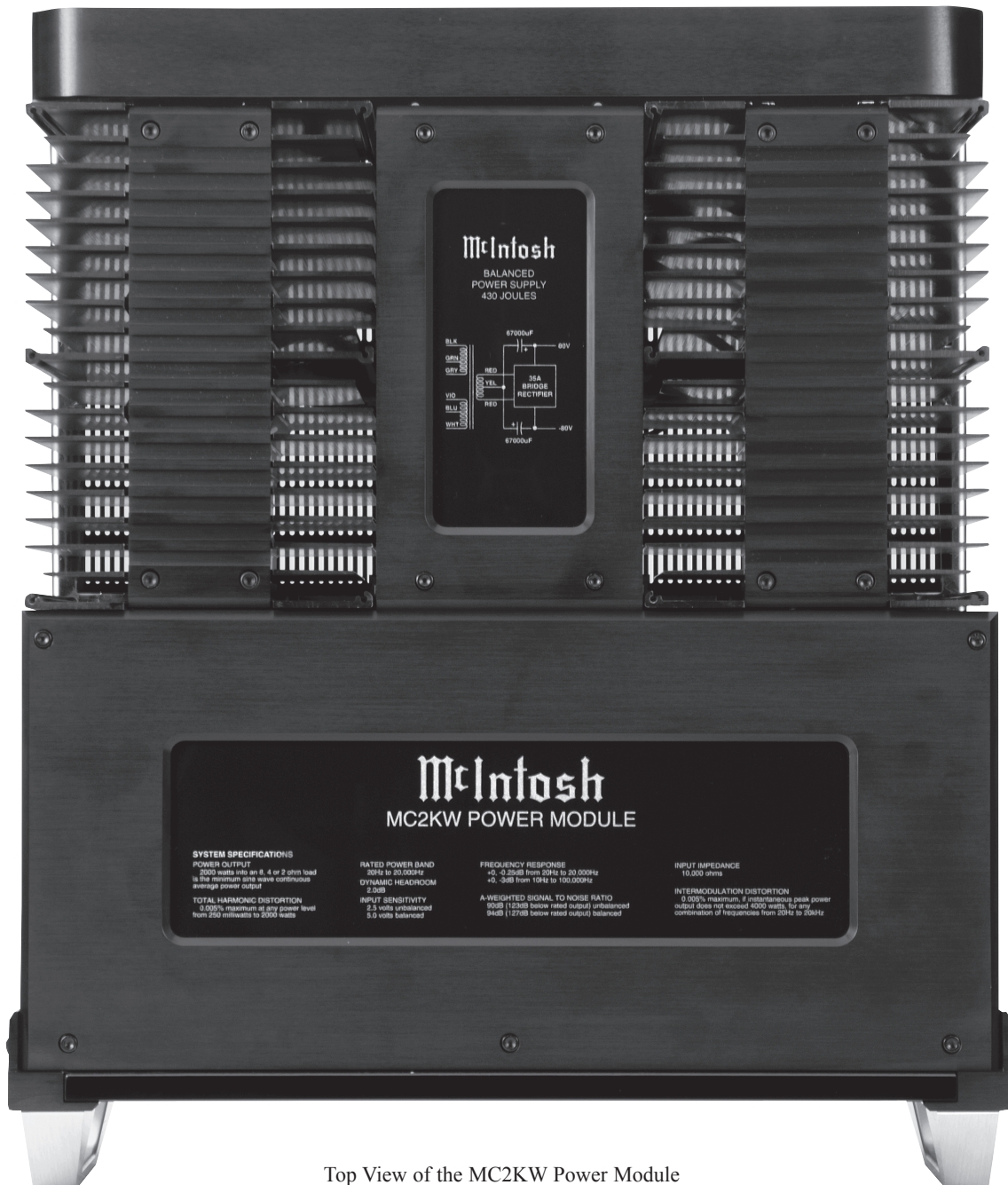

Top View of the MC2KW Power Module

quencies is less than 0.002%. The true distortion readings on the MC2KW Power Amplifier are so low, it takes special measuring techniques to make accurate readings. The MC2KW Power Amplifier can deliver the best possible performance from any type of high quality Loudspeaker System.

Creating an amplifier with this level of performance did not come easily. Many months of design, testing and measuring were required. Extensive controlled listening tests, the ultimate form of measuring, were made before the final design was accepted.

Design Philosophy

The design philosophy incorporated in the MC2KW Power Amplifier involved several different techniques, all based on sound scientific logic. Every stage of voltage or current amplification must be as linear as possible prior to the use of negative feedback. McIntosh Engineers know how to properly design negative feedback circuits so they contribute to the extremely low distortion performance expected from a McIntosh Amplifier. The typical McIntosh owner would never accept the approximately 100 times higher distortion of many non-feedback designs.

All transistors are selected to have nearly constant current gain over the entire current range they must cover. The 48 Power Transistors used in each MC2KW Power Module Output Circuitry, have matched uniform current gain, high current bandwidth product and a large active region safe operating area. These Power Transistors are the very latest in semiconductor technology and incorporate a new design known as ThermalTrak¹. Refer to figure 17. This allows for the instantaneous and accurate monitoring of the Power Transistor Temperature. Each of the MC2KW Power Modules has a specially designed bias circuit to take full advantage of the ThermalTrakTM Power Transistors and thus precisely controls the power amplifier operation over a wide range of music conditions with the benefits of lower distortion and cooler operation. Precision metal film resistors and low dielectric absorption film capacitors are used in all critical circuit locations.

Each of the two MC2KW Power Modules utilizes a Double Balanced Push-Pull design used from input to output. Each half of the amplifier contains complimentary balanced circuitry. Refer to figure 18. The resulting double bal-



Figure 17

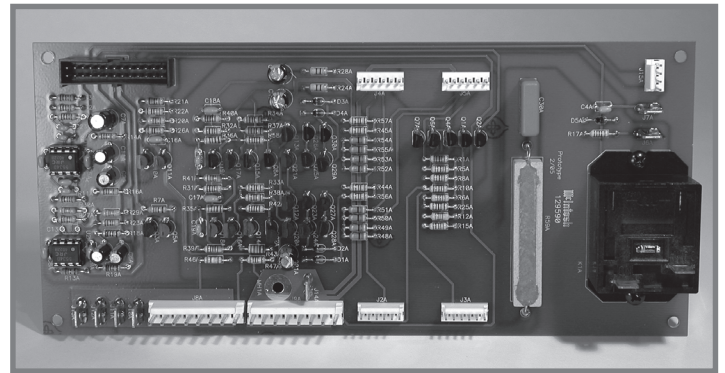

Figure 18

anced configuration cancels even order distortion. The output signals from the two MC2KW Power Modules are coupled together in the unique McIntosh MC2KW Power Amplifier Output Autoformer. It provides low distortion power transfer at frequencies from below 20Hz to well beyond 20,000Hz with optimum impedance points of two ohms, four ohms and eight ohms. The unequalled expertise of McIntosh in the design and manufacturing of autoformers is legendary in the high fidelity industry. The high efficiency circuit design of the MC2KW Power Amplifier contributes to low operating temperatures. More than 2,800 square inches of heat sink area for each MC2KW Power Module keep the Power Amplifier operating safely with convection cooling. No fans are needed. Refer to figure 19.

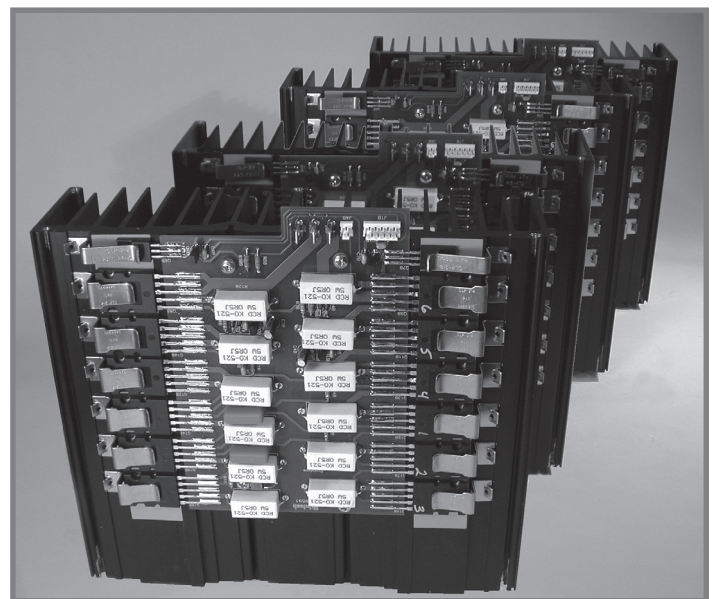

Figure 19

¹ThermalTrakTM and ON Semiconductor are trademarks of Semiconductor Components Industries, LLC



Autoformer

All solid state power amplifier output circuits work best into what is called an optimum load. This optimum load may vary considerably from what a loudspeaker requires. In the case of more than one loudspeaker connected in parallel, the load to the power amplifier may drop to two ohms or even less. A power amplifier connected to a load that is lower than optimum, causes more output current to flow, which results in extra heat being generated in the power output stage. This increase in temperature will result in a reduced life expectancy for the amplifier.

The special Balanced Dual “C” Core Autoformer creates an ideal match between the power amplifier output stage and the loudspeaker. Refer to figure 20. A McIntosh amplifier with an Autoformer can be used to safely drive multiple



Figure 20

speakers without reducing the life expectancy of the power amplifier.

There is absolutely no performance limitation with an Autoformer. Its frequency response exceeds that of the output circuit itself, and extends well beyond the audible range. Its distortion level is so low it is virtually impossible to measure.

In the rare event of a power amplifier output circuit failure, the McIntosh Autoformer provides absolute protection from possible damage to valuable loudspeakers. The unequalled expertise of McIntosh in the design and manufac-

turing of Autoformers is legendary in the high fidelity industry. McIntosh Engineers know how to do it right.

Power Output Meter

The McIntosh MC2KW Power Amplifier has a huge hand built Output Watt Meter that responds 95% full scale to a single cycle tone burst at 2kHz. Refer to figure 21. Voltage

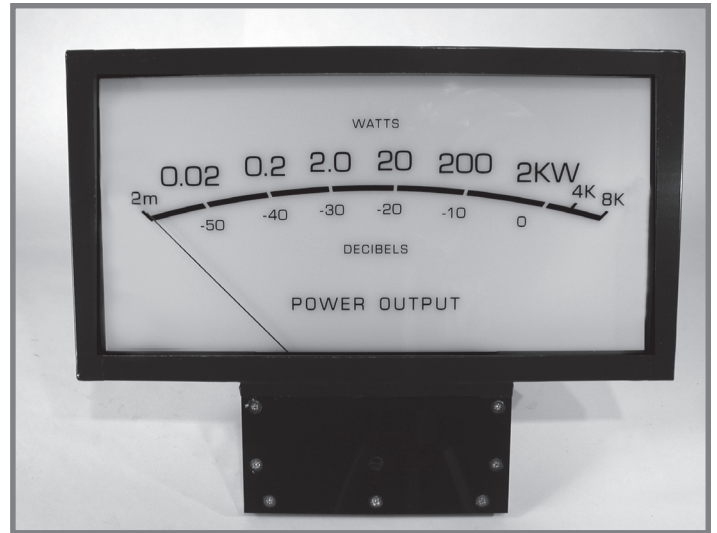

Figure 21

and current output are electronically measured, multiplied and fed to a special circuit that accelerates the pointer movement in the upward direction. When the pointer reaches its peak it pauses only long enough for the human eye to perceive its position, then drops. It is almost 10 times faster than a professional VU meter.

A front panel switch is provided to change the meter to the Watts Hold Mode of operation. This allows fast upward movement of the pointer but greatly increases Hold Time at the peak of its travel. The highest power output of the source material is thus recorded.

Protection Circuits

The MC2KW Power Amplifier incorporates the McIntosh Sentry Monitor Output Transistor Protection Circuit. Refer to Figure 22.

There is absolutely no compromise in sonic performance with this circuit, and it ensures safe operation of the amplifier under even the most extreme operating condi-

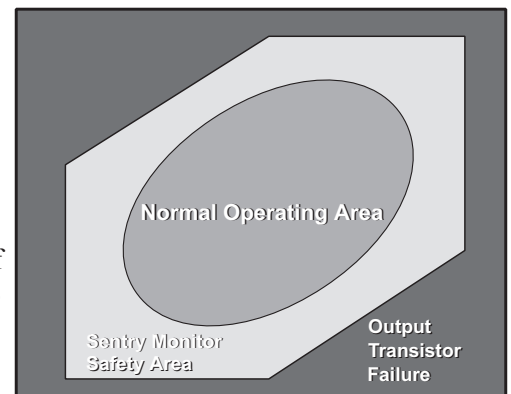

Figure 22

tions. The different types of protection circuits incorporated in the MC2KW Power Amplifier insure a long and safe operating life. This is just one of the many characteristics of McIntosh Power Amplifiers that make them world famous.

The MC2KW Power Amplifier also includes the unique patented McIntosh Power Guard circuit. Power Guard eliminates the possibility of ever overdriving the amplifier into clipping. Refer to figures 23, 24 and 25. An overdriven amplifier can produce both audible and inaudible distortion levels exceeding 40%. The audible distortion is unpleasant to hear, but the inaudible ultra-sonic distortion is also undesirable, since it can damage valuable loudspeaker system tweeters. You will never experience the harsh and damaging distortion due to clipping.

The Power Guard circuit is a waveform comparator, monitoring both the input and output waveforms. Under normal operating conditions, there are no differences between the shape of these waveforms. If an amplifier channel is overdriven, there will be a difference between the two signal waveforms. When the difference exceeds 0.3% (equivalent to 0.3% harmonic distortion), the Power Guard activates the PG light and a dynamic electronic attenuator at the amplifier input reduces the input

volume just enough to prevent any further increase in distortion. The Power Guard circuit acts so fast that there are absolutely no audible side effects and the sonic purity of the music reproduction is perfectly preserved. The MC2KW Power Amplifier with Power Guard is not limited to just the rated power output, but will actually produce distortion free output well above its rated power due to the McIntosh philosophy of conservative design.

Power Supply Circuits

To compliment the fully balanced design of the MC2KW Power Amplifier there is a high current, high voltage power supply inside each of the MC2KW Power Modules. The very large Power Transformer has a toroidal windings on a toroidal core. Refer to figure 26 (the golf ball is for size comparison). It is enclosed in the legendary McIntosh Potted Enclosures and weighs over 26.6 pounds (12.06kg).

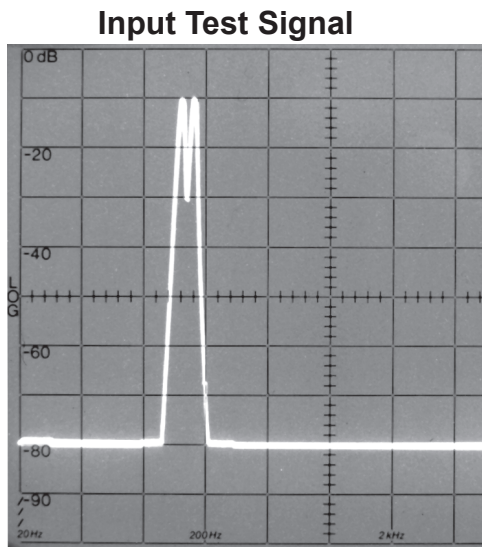

Figure 23

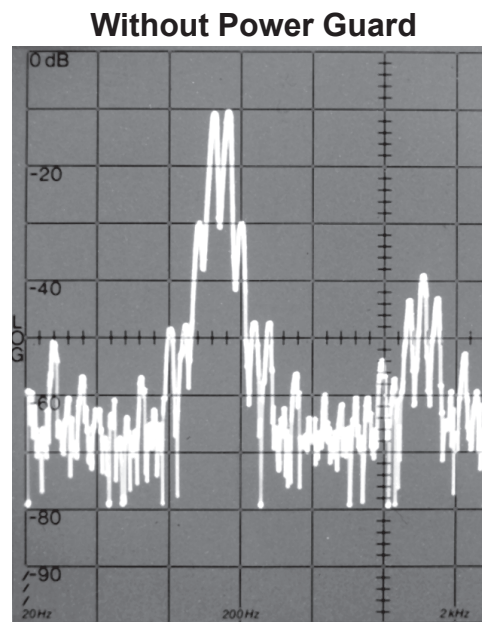

Figure 24

With Power Guard

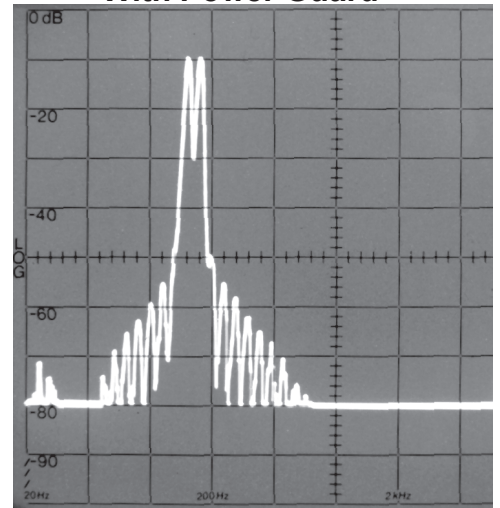

Figure 25

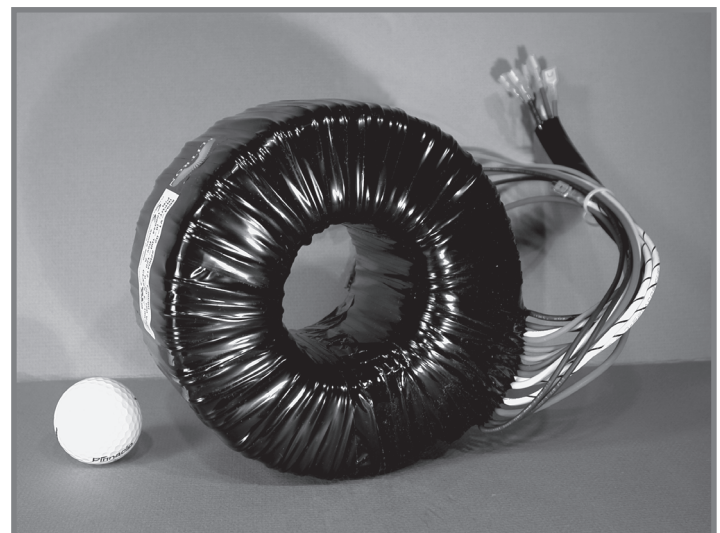

Figure 26

The super size main filter capacitors can store over 430 Joules of energy necessary for the wide dynamic range that

music demands and guarantees an excellent signal to noise ratio. Refer to figure 27.



Figure 27

The MC2KW Output Module contains the low voltage regulated power supplies for each of the MC2KW Power Modules and for the Input Audio circuitry located inside the MC2KW Output Module. Refer to figure 28. The special

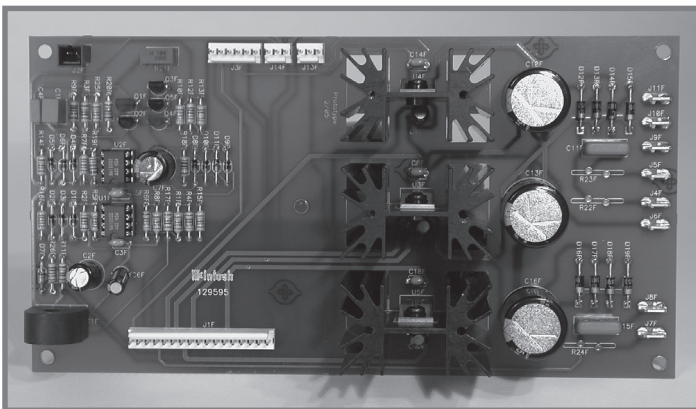

Figure 28

“R” core transformer supplies the necessary voltage/current for the low voltage regulated circuitry and is housed in a shielded enclosure. Refer to figure 29.

Most owners desire one power switch for the whole audio system. The MC2KW Power Amplifier is equipped with a cir-

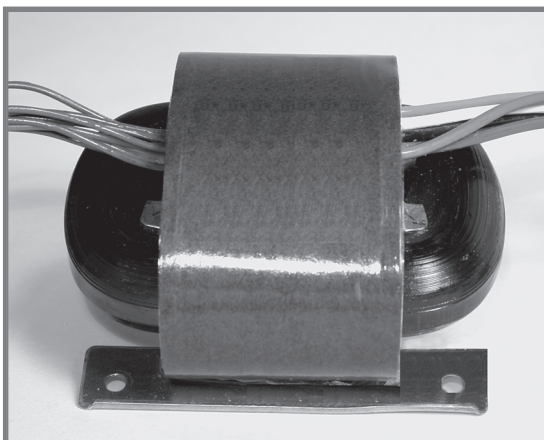

Figure 29

cuit that provides remote Power Control from a McIntosh Preamplifier or A/V Control Center. When the Preamplifier or A/V Control Center is switched On a digital “1” (+5V) signal changes the operational state of digital control circuitry and a DC voltage is sent to each MC2KW Power Module to activate the power relay. The two MC2KW Power Modules return an acknowledgment signal to the digital control circuitry and the MC2KW Output Module is then allowed to switch On. Refer to figure 30.

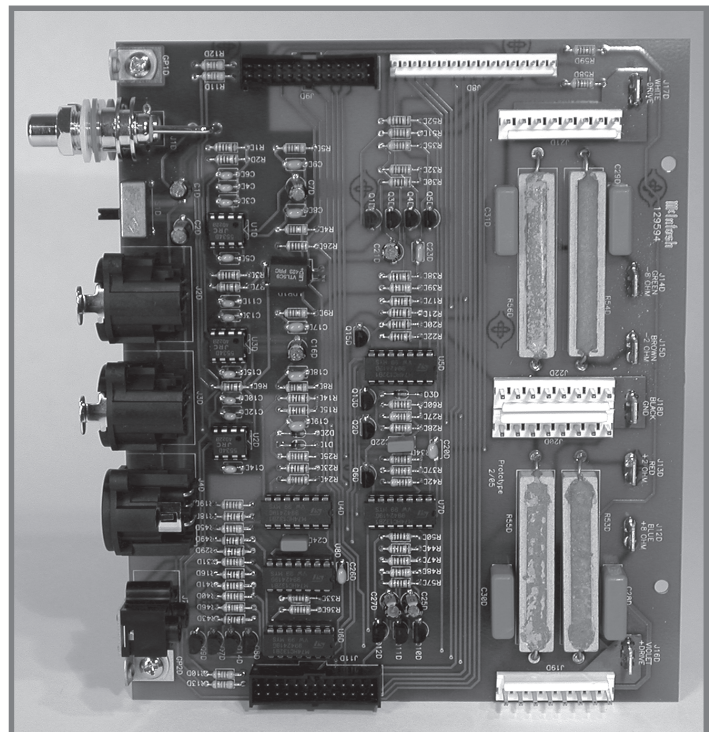

Figure 30

The MC2KW Power Amplifier also has a remote Power Control Out Jack. The Power Control signal from this jack is delayed by a fraction of a second so that the turn on power surge of the next power amplifier occurs at a later time. This helps prevent power circuit overload that could trip circuit breakers or blow fuses, a very important feature when multiple MC2KW Power Amplifiers are used.



Top View of the MC2KW Output Module



Front View of the MC2KW Output Module



Front View of the MC2KW Power Module

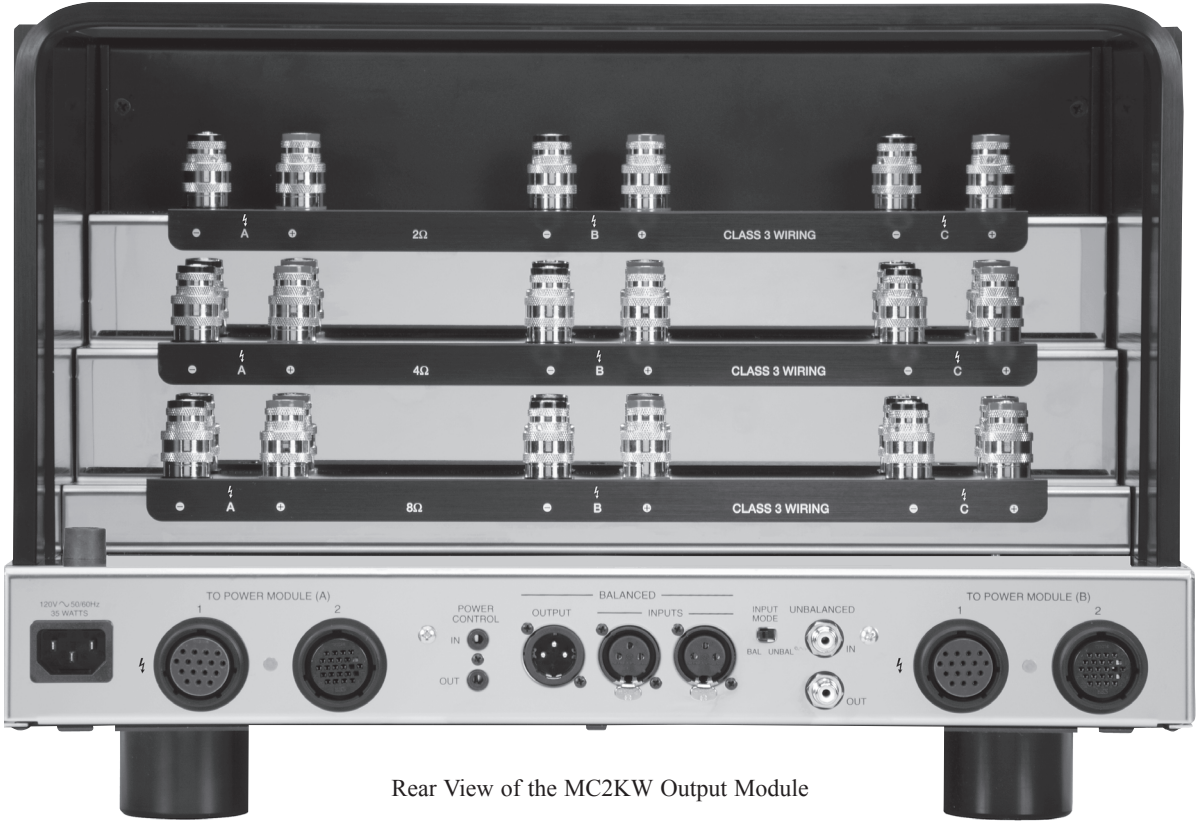

Rear View of the MC2KW Output Module



Rear View of the MC2KW Power Module



Angle View of the MC2KW Output Module



Angle View of the MC2KW Power Module

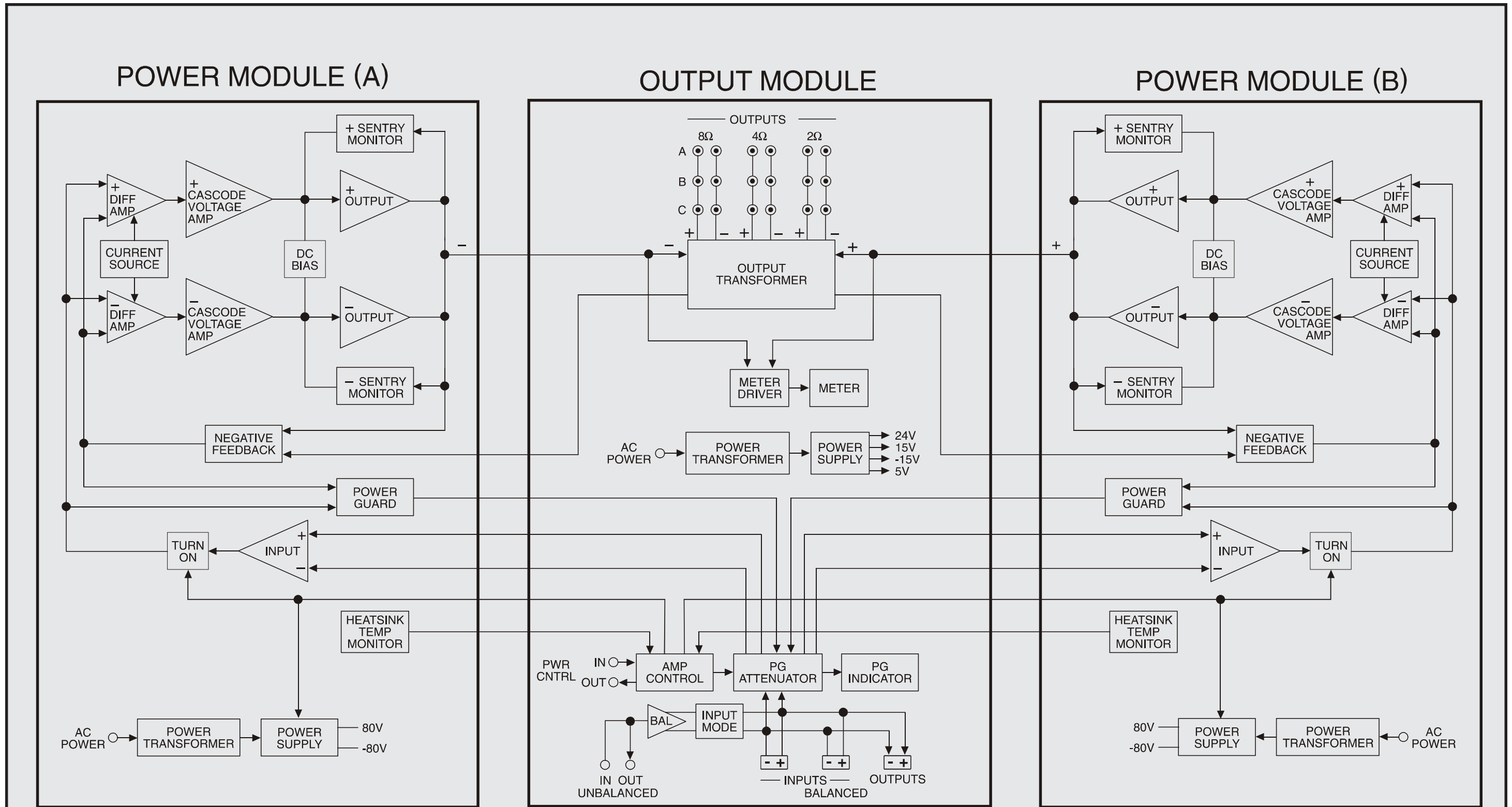

MC2KW Power Amplifier - Output Module with Power Modules A and B



Power Amplifier Specifications

Power Output
 2000 watts into an 8, 4 or 2 ohm load is the minimum sine wave continuous average power output. The output RMS voltage is:
 126.5V across 8 ohms
 89.5V across 4 ohms
 63.3V across 2 ohms

Output Load Impedance
 8, 4 and 2 ohms (with three pairs of terminals each for impedance)

Rated Power Band
 20Hz to 20,000Hz

Total Harmonic Distortion
 0.005% maximum harmonic distortion at any power level from 250 milliwatts to 2000 watts, 20Hz to 20,000Hz

Dynamic Headroom
 2dB

Frequency Response
 +0, -0.25dB from 20Hz to 20,000Hz
 +0, -3dB from 10Hz to 100,000Hz

Sensitivity
 5.0 Volts Balanced Input
 2.5 Volts Unbalanced Input

A-Weighted Signal To Noise Ratio
 90dB Unbalanced (123dB below rated output)
 94dB Balanced (127dB below rated output)

Intermodulation Distortion
 0.005% maximum, if instantaneous peak power output does not exceed 4000 watts, for any combination of frequencies from 20Hz to 20kHz.

Wide Band Damping Factor
 Greater than 40

Input Impedance
 10,000 ohms

Power Guard
 Less than 2% THD with up to 14dB overdrive

General Specifications

MC2KW Output Module Power Requirements
 100 Volts, 50/60Hz at 35 watts
 110 Volts, 50/60Hz at 35 watts
 120 Volts, 50/60Hz at 35 watts
 220 Volts, 50/60Hz at 35 watts
 230 Volts, 50/60Hz at 35 watts
 240 Volts, 50/60Hz at 35 watts

MC2KW Power Module Power Requirements¹
 100 Volts, 50/60Hz at 1440 watts
 110 Volts, 50/60Hz at 13.0 amps
 120 Volts, 50/60Hz at 12.0 amps
 220 Volts, 50/60Hz at 7.5 amps
 230 Volts, 50/60Hz at 6.5 amps
 240 Volts, 50/60Hz at 6.5 amps

Note: Refer to the rear panels of the MC2KW Output Module and MC2KW Power Modules for the correct voltage.

Overall Dimensions

MC2KW Output Module:
 Width is 17-3/4 inches (45.09cm)
 Height is 12-5/16 inches (31.27cm) including feet
 Depth is 26-5/8 inches (62.54cm) including the Front Panel, Handles, Knobs and Interconnect Cables²

MC2KW Power Module:
 Width is 17-3/4 inches (45.09cm)
 Height is 12-5/16 inches (31.27cm) including feet
 Depth is 26-5/8 inches (62.54cm) including the Front Panel, Handles, and Interconnect Cables²

Weight

MC2KW Output Module - 121 pounds (54.9 kg) net
 146 pounds (66.2 kg) in shipping carton

MC2KW Power Module - 158 pounds (71.7 kg) net
 183 pounds (83.0 kg) in shipping carton

¹ The Power Requirements listed are for each MC2KW Power Module, two are required for each MC2KW Power Amplifier
² Interconnect Cables are supplied with the MC2KW Output Module and both MC2KW Power Modules connect to the MC2KW Output Module

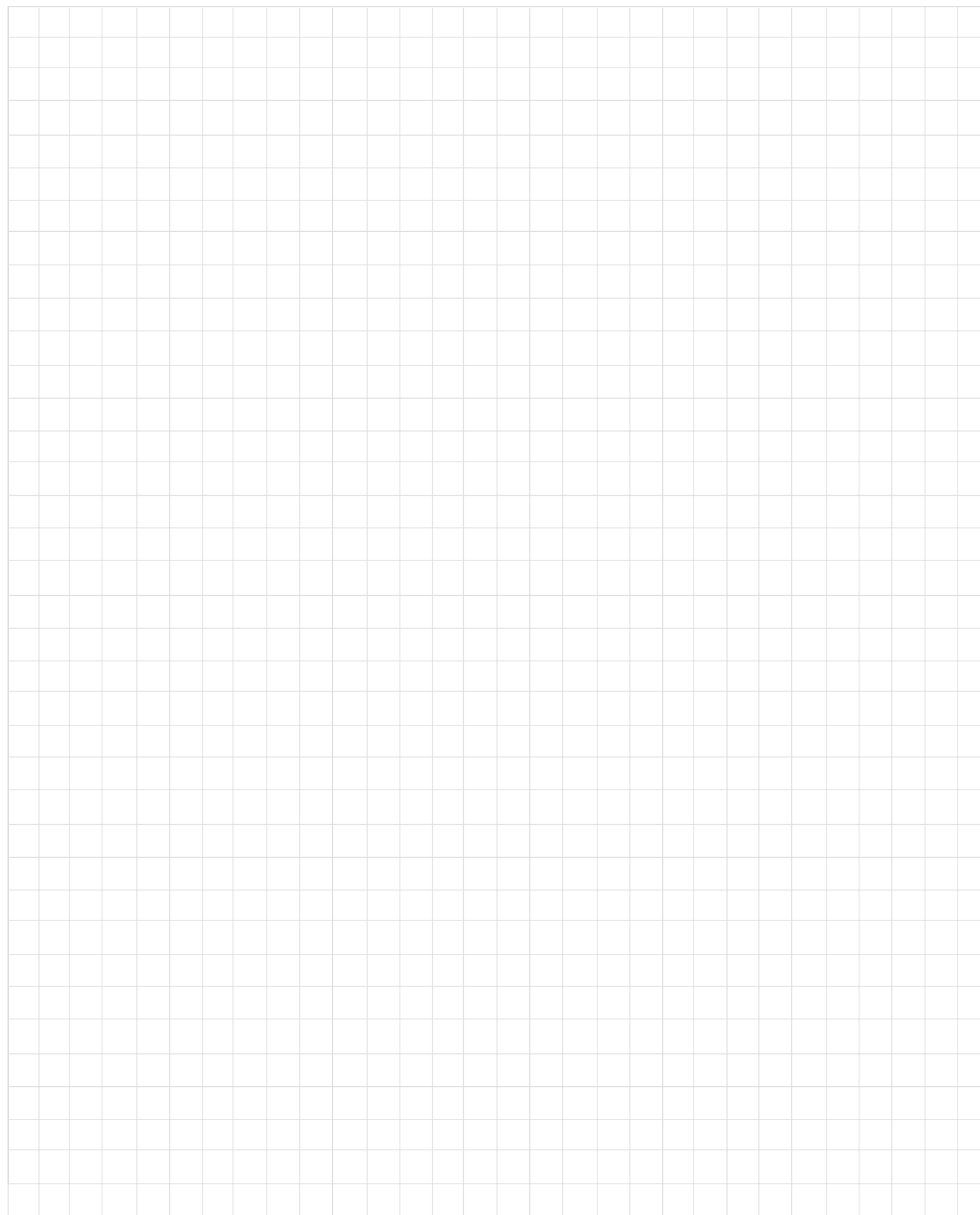

Packing Instructions

In the event it is necessary to repack the equipment for shipment, the equipment must be packed exactly as shown below. It is very important that the four feet are attached to the bottom of the equipment. This will ensure the proper equipment location on the bottom foam pad. Failure to do this will result in shipping damage. Also, to protect the finish of the glass and metal surfaces it is advisable to place the MC2KW Output Module and the MC2KW Power Modules into the original protective cotton blue bag before placing them into the shipping carton.

Note: Unless instructed otherwise, please return the McIntosh Custom Interconnect Cables along with the MC2KW Power Amplifier.

Use the original shipping carton and interior parts only if they are all in good serviceable condition. If a shipping car-

ton or any of the interior part(s) are needed, please call or write Customer Service Department of McIntosh Laboratory. Please see the Part List for the correct part numbers.

Note: The McIntosh MC2KW Output Module and MC2HW Power Module use the same shipping carton.

Quantity	Part Number	Description
1	034104	Shipping carton bottom
1	034105	Shipping carton top
1	034356	Protective blue cloth cover
4	018445	Feet
3	034349	Foam ring
2	034349	Foam pad (top and bottom)
1	034341	Shipping carton for interconnect cables

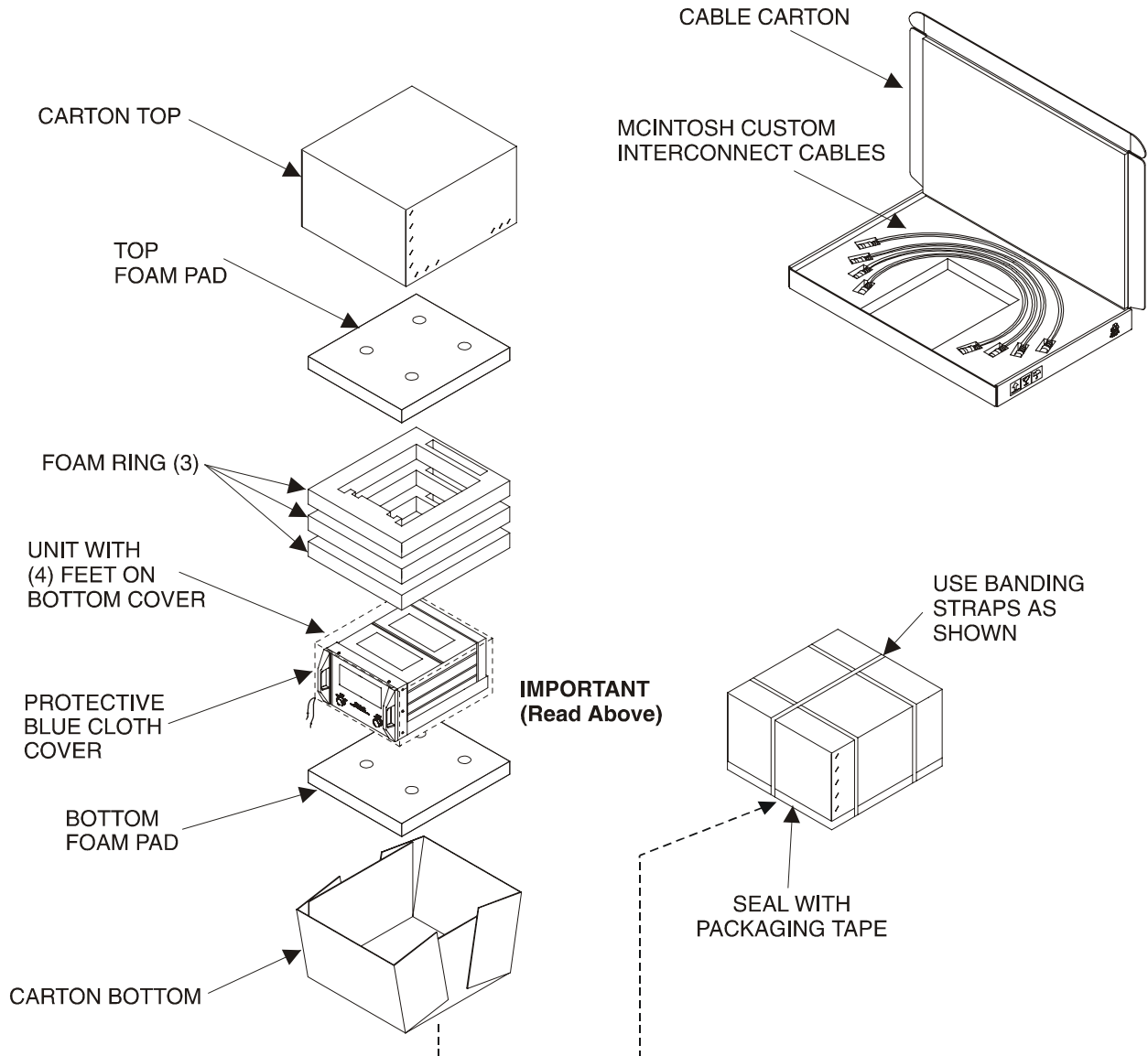



McIntosh Laboratory, Inc.
2 Chambers Street
Binghamton, NY 13903

The continuous improvement of its products is the
policy of McIntosh Laboratory Incorporated who
reserve the right to improve design without notice.
Printed in the U.S.A.

McIntosh Part No. 04094600